

NCERT

# Manual of Secondary Science Kit

Classes IX and X

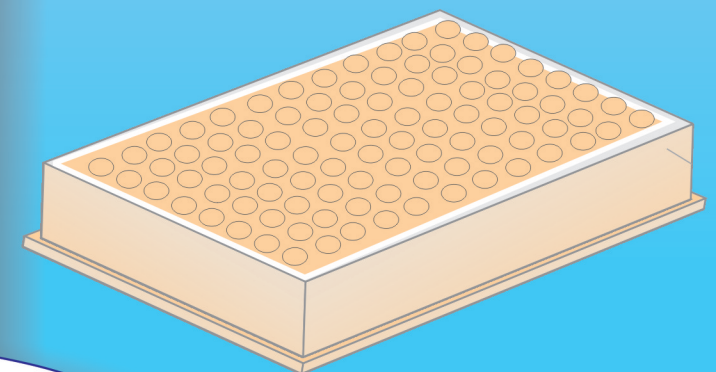
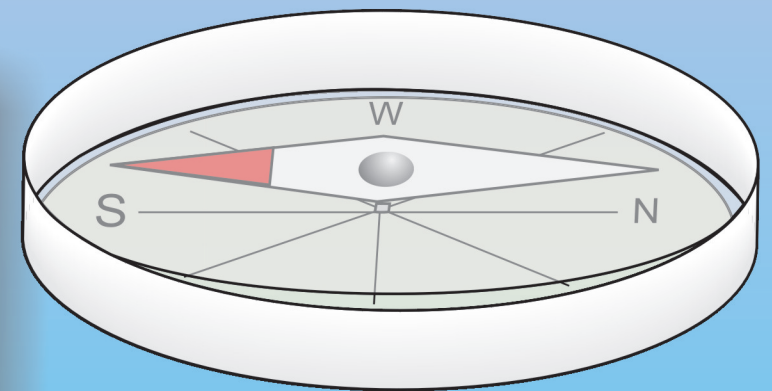
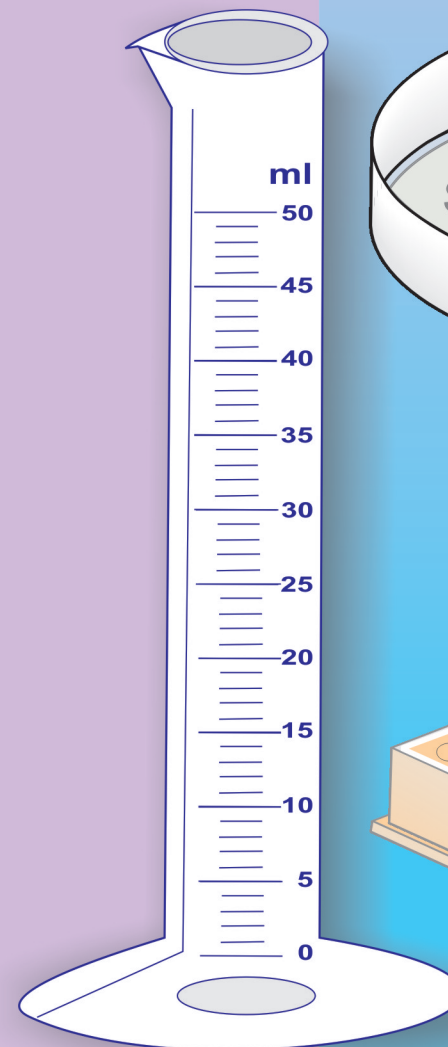
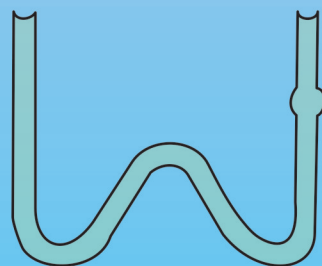

विद्यया ऽ मृतमश्नुते



एन सी ई आर टी  
NCERT

राष्ट्रीय शैक्षिक अनुसंधान और प्रशिक्षण परिषद्  
NATIONAL COUNCIL OF EDUCATIONAL RESEARCH AND TRAINING

Manual of Secondary Science Kit

Classes IX and X

NCERT



# Manual of Secondary Science Kit

Classes IX and X

विद्यया ऽ मृतमश्नुते



एन सी ई आर टी  
NCERT

राष्ट्रीय शैक्षिक अनुसंधान और प्रशिक्षण परिषद्  
NATIONAL COUNCIL OF EDUCATIONAL RESEARCH AND TRAINING

**First Edition**

November 2010 Aagrahayana  
1932

**PD 1T VK**

© **National Council of  
Educational Research and  
Training, 2010**

**Rs 00.00**

*Printed on 80 GSM paper*

Published at the Publication  
Department by the Secretary,  
National Council of Educational  
Research and Training, Sri  
Aurobindo Marg, New Delhi  
110016 and printed at .. .....  
.....  
.....

**ALL RIGHTS RESERVED**

- No part of this publication may be reproduced, stored in a retrieval system or transmitted, in any form or by any means, electronic, mechanical, photocopying, recording or otherwise without the prior permission of the publisher.
- This book is sold subject to the condition that it shall not, by way of trade, be lent, re-sold, hired out or otherwise disposed of without the publisher's consent, in any form of binding or cover other than that in which it is published.
- The correct price of this publication is the price printed on this page. Any revised price indicated by a rubber stamp or by a sticker or by any other means is incorrect and should be unacceptable.

**OFFICES OF THE PUBLICATION  
DEPARTMENT, NCERT**

NCERT Campus  
Sri Aurobindo Marg  
**New Delhi 110 016** Phone : 011-26562708

108, 100 Feet Road  
Hosdakere Halli Extension  
Banashankari III Stage  
**Bangaluru 560 085** Phone : 080-26725740

Navjivan Trust Building  
P.O. Navjivan  
**Ahmedabad 380 014** Phone : 079-27541446

CWC Campus  
Opp. Dhankal Bus Stop  
Panihati  
**Kolkata 700 114** Phone : 033-25530454

CWC Complex  
Maligaon  
**Guwahati 781 021** Phone : 0361-2674869

**Publication Team**

Head, Publication : *Neerja Shukla*  
Department

Chief Production : *Shiv Kumar*  
Officer

Chief Editor : *Shveta Uppal*

Chief Business : *Gautam Ganguly*  
Manager

Editor : *Vijay Kumar*

Production Assistant:

**Cover**

*Manoj Dubey*

**Illustrations**

*Manoj Dubey, Rishi*

## **PREFACE**

This Manual of Secondary Science Kit for Classes IX and X not only describes the kit items and their uses, but also details the activities based on NCERT IX and X science textbooks. Moreover, the experiments prescribed for Classes IX and X practicals by CBSE can also be done using this kit. Thus, the Science Kit serves as a portable laboratory whereas the manual supplements the science textbooks.

The activities in the manual are structured in a manner so that the students can question, explore and finally discover the concepts involved. The manual is based on an approach wherein attempts are made to inculcate the scientific enquiry and understanding of the subject matter among the students. The success and usefulness of the kit with manual will depend on how best the teachers can motivate the students to use the items rather than a mere demonstration by them.

Such an activity based approach has been followed in preparation of the science textbooks in the NCERT and which requires that the students themselves do the different activities. In the process of doing the activities using the present science kit not only will the students feel the excitement, but it will also give them opportunities to think and explore and which may not be achievable by a reading of the textbooks alone. Of course, this requires time and keen interest on the part of the teachers. It is hoped that the teachers would also enjoy making use of the kit and the manual.

One of the significant reforms in chemistry laboratory practices has been the adoption of microscale technique throughout the world. This technique not only cuts the cost of the chemicals and apparatuses to a considerable extent, but also is safe and environment friendly. The various activities in chemistry are described using the items of the kit based on the microscaler approach.

The NCERT appreciates the hand work done by the experts, teachers, Workshop technical staff, Publication Department staff in the development of the kit and the manual. Special thanks are



due to Prof. Dharam Prakash, NIE (Workshop), NCERT, Dr. Kuldeep Singh, Reader, NIE (Workshop), NCERT and Dr. Gagan Gupta, Reader, DESM , NCERT, who contributed significantly in preparation of the manual and kit.

H.O. Gupta  
*Professor and Head*  
NIE, Workshop Department

## ACKNOWLEDGEMENT

The National Council of Educational Research and Training (NCERT), expresses its gratefulness to Dr. K.K. Arora, Reader (Chemistry), Department of Chemistry, Zakir Hussain College, New Delhi; Shri. J.P. Agarwal, Principal (Retd), Ashok Vihar -III, New Delhi; Dr. K.K. Gupta, Reader (Retd), Shalimar Bagh, New Delhi; Dr Vijay Sharda, Reader, Department of Chemistry, Zakir Hussain College, New Delhi; Dr. Gita Mathur, Reader in Botany, Department of Botany, Gar gi College, Siri Fort Road, New Delhi; Prof. Ved Ratna (Retd.), Saraswati Vihar, New Delhi; Shri Kanhaiya Lal, Principal (Retd.), Delhi Gate, Ghaziabad; Prof. Sunita Malhotra, Director, School of Science, IGNOU; Dr. Rashmi Sharma, Lecturer in Chemistry, NERIE, Shillong; Prof. B.B. Swain, Bhubaneswar (Orissa); Dr. A.K. Vashistha, Principal, G.B. S.S.S., Jafrabad; Shri Raja Kishore Nayak, TGT, DMS, RIE Ajmer; Shri. Anil Kumar Jena, TGT, DMS, RIE Bhubaneswar; Prof. H.C. Jain, (Retd. Principal), RIE Ajmer; Mrs. Sini Annie Abraham, TGT, DPS, R.K. Puram, Sec-12, New Delhi; Dr. Babeeta Chrungu Kaula, Sr. Lecturer, Department of Botany, Zakir Hussain College, New Delhi; Dr. Sarita Kumar, Reader, Acharya Narendra Dev College, New Delhi; Satheesh H.L, TGT, DMS, Mysore; Mrs. Nishi Saraswat, PGT, Kendriya Vidyalaya-I, Delhi; Prof. S.C. Jain, RIE, Bhubaneswar; Mrs Vandana Singh, TGT, Kendriya Vidyalaya, JNU, New Delhi; Mr. D.C. Pandey, Jalvayu Vihar, Noida; Mr. R.S. Dass, (Retd.) Vice Principal, Vaishali, Ghaziabad; Dr. S.V. Sharma, Sr. Lecturer in Physics, RIE, Ajmer; Mrs. Amina Ansari, TGT, Sardar Patel Vidyalaya Lodhi Estate, New Delhi; Mr. Johnson David, (Retd. Lecturer), Biology, E-215, Saraswati Kunj Society, Plot No.25, I.P. Extension Delhi; Mrs. Raji Kamlasanan, PGT, DTEA Sr. Sec. School, R.K. Puram, Sec-4, New Delhi; Mrs. Meeta Purkayastha, PGT, New State Academy Senior Sec. School, Pitampura, New Delhi; Sunila Masin, TGT, Friends Girl's Higher Secondary School, Sohappur M.P; Pradeep Kumar Sharma, Govt. M. School, M.P; Mandharlal Patel, Govt. R.N.A, Sr. Secondary School, Piperiya, M.P; Mr. R.P. Sharma, Education Officer Science, CBSE, Siksha Sadan, 17, Rouse Avenue, New Delhi; S.L.Varte, Lecturer, DESM,

NCERT; Prof. R.S. Sandhu, DESM, NCERT; for their contribution in the development, reviewing, editing, refining and finalisation of the manuscript of the “ Manual of Secondary Science Kit” for Classes IX and X.

Special thanks are due to Dr. Kuldeep Singh, Reader, NIE, Workshop, NCERT, New Delhi; Prof. Dharam Prakash, NIE, Workshop, NCERT, New Delhi; Dr. S.K. Dash, Reader, RIE, Bhubaneswar; Dr. Gagan Gupta, Reader, DESM, NCERT, New Delhi, for their significant contribution in preparation of the manual and the kit.

The Council acknowledges the supports and facilities provided by NIE, Workshop and its staff; Shri Anil Nayal (Draftsman), Shri Manoj Dubey (JPF); Shri Ajay Ambwani (Computer Assistant); Shri Ramesh Kumar (DTP Operator) and Davendra Kumar Sikka (UDC) for development of the Kit Manual and technical support of Shri P. Chandra, Shri. G.D. Sharma (technician), Shri Narendra Kumar, Shri Attar Singh, Shri Amarnath, Shri Satish Sharma, Shri Rambhool Singh and Shri Rajendra Kumar of NIE, Workshop, NCERT, New Delhi.

## CONTENTS

<b>Preface</b>	<i>iii</i>
<b>1 NCERT Secondary Science Kit</b>	<b>1-4</b>
<b>2 List of Secondary Science Kit Items</b>	<b>5-22</b>
<b>Activities</b>	
<b>9.1 Matter in Our Surroundings</b>	<b>23-27</b>
ACTIVITY 9.1.1	How will you show and compare the compressibility of gases and liquids?
ACTIVITY 9.1.2	How will you determine the boiling point of water and melting point of ice?
ACTIVITY 9.1.3	How will you study the phenomenon of sublimation?
ACTIVITY 9.1.4	How does the rate of evaporation of different liquids differ?
<b>9.2 Is Matter Around Us Pure</b>	<b>28-39</b>
ACTIVITY 9.2.1	How to prepare the saturated solution of common salt in distilled water?
ACTIVITY 9.2.2	How to prepare a solution of common salt of 10 per cent composition by volume.
ACTIVITY 9.2.3	How to separate the components of a mixture containing sand, common salt and camphor?
ACTIVITY 9.2.4	How to prepare and identify a homogenous mixture and a heterogeneous mixture?
ACTIVITY 9.2.5	How to differentiate between a homogenous solution, colloidal solution and suspension on the basis of transparency, filtration and Tyndal effect?
ACTIVITY 9.2.6	How to separate a mixture of two immiscible liquids?
ACTIVITY 9.2.7	How to differentiate between a mixture and a compound?
<b>9.3 Atoms and Molecules</b>	<b>40-41</b>
ACTIVITY 9.3.1	How to verify the law of conservation of mass in a chemical reaction?

<b>9.4 Structure of the Atom</b>	<b>42</b>
ACTIVITY 9.4.1	How to build static model of electron distribution in atoms in different orbits of first eighteen atoms?
<b>9.5 The Fundamental Unit of Life</b>	<b>43-52</b>
ACTIVITY 9.5.1(a)	How to study the parts of a dissection microscope and their functions?
ACTIVITY 9.5.1(b)	How to study the parts of a compound microscope and their functions?
ACTIVITY 9.5.2(a)	How to study plant cells?
ACTIVITY 9.5.2(b)	How to study animal cells?
ACTIVITY 9.5.3	How to study the process of osmosis?
ACTIVITY 9.5.4	How to study the processes of plasmolysis and deplasmolysis?
<b>9.6 Tissues</b>	<b>53-55</b>
ACTIVITY 9.6.1	How to identify the different types of plant tissues?
ACTIVITY 9.6.2	How to identify different types of animal tissues?
<b>9.7 Diversity in Living Organisms</b>	<b>56-68</b>
ACTIVITY 9.7.1	How to study diversity in plants?
ACTIVITY 9.7.2	How to differentiate a dicot from a monocot plant?
ACTIVITY 9.7.3	How to prepare a herbarium sheet?
ACTIVITY 9.7.4	How to study diversity in animals?
ACTIVITY 9.7.5	How to study the life cycle of an insect?
ACTIVITY 9.7.6	How to study the life cycle of malarial parasite (Plasmodium)?
ACTIVITY 9.7.7	How to study diseases in locally available crops?
<b>9.8 Motion</b>	<b>69</b>
ACTIVITY 9.8.1	How to determine the direction of motion of a body moving in a circular path?
<b>9.9 Force and Laws of Motion</b>	<b>70-76</b>
ACTIVITY 9.9.1(a)	How are the directions of action and reaction forces related?
ACTIVITY 9.9.1(b)	Are the direction of action and reaction forces related?

- ACTIVITY 9.9.2 How to demonstrate third law of motion?  
ACTIVITY 9.9.3 Does the total momentum of a system of bodies remain the same when they collide?

**9.10 Gravitation 77-83**

- ACTIVITY 9.10.1 Does the pressure depend upon area on which the force is exerted?  
ACTIVITY 9.10.2 How does the pressure vary with the depth of a liquid?  
ACTIVITY 9.10.3 Why do you feel an upward push when a solid is immersed in a liquid?  
ACTIVITY 9.10.4 How can you determine that the density of a solid denser than water?  
ACTIVITY 9.10.5 Does a body experience a buoyant force when it is immersed fully or partially in a liquid? What is the relation between this force and the weight of the liquid displaced by the body?

**9.11 Work and Energy 84-86**

- ACTIVITY 9.11.1 How to determine if potential energy possessed by an object depend upon its position or configuration?  
ACTIVITY 9.11.2 Are potential and kinetic energies interconvertible?

**9.12 Sound 87-92**

- ACTIVITY 9.12.1 Are vibrations essential for producing sound?  
ACTIVITY 9.12.2 How can you produce longitudinal waves in a slinky?  
ACTIVITY 9.12.3 How can you determine the speed of a pulse propagated through a stretched slinky?  
ACTIVITY 9.12.4 How can you study the reflection of sound?

**10.1 Chemical Reactions and Equations 93-101**

- ACTIVITY 10.1.1 How do we know that a chemical reaction has taken place?  
ACTIVITY 10.1.2 What are the different types of chemical reactions?  
ACTIVITY 10.1.3 What happens when an electric current is passed through water?  
ACTIVITY 10.1.4 How will you study a redox reaction?

**10.2 Acids, Bases and Salts 102-114**

- ACTIVITY 10.2.1 How will you identify the acidic and basic nature of substances using different indicators?

- ACTIVITY 10.2.2 What are the chemical properties of acids and bases?
- ACTIVITY 10.2.3 How will you estimate the pH of given substances using pH paper/ universal indicator solution?
- ACTIVITY 10.2.4 How can you identify bleaching powder, washing soda and baking soda from given samples X, Y and Z .
- ACTIVITY 10.2.5 How will you show that crystals of copper sulphate contain water of crystallisation?
- ACTIVITY 10.2.6 How will you prepare  $\text{SO}_2$  gas and draw inference in respect of its:  
(i) effect on litmus paper.  
(ii) action on acidified  $\text{K}_2\text{Cr}_2\text{O}_7$ .  
(iii) solubility in water.

**10.3 Metals and Non-metals****115-124**

- ACTIVITY 10.3.1 How will you compare the physical properties of metals and non-metals?
- ACTIVITY 10.3.2 How will you study the chemical properties of metals by observing their reactions with air, water and acids?
- ACTIVITY 10.3.3 What is the action of metals such as Zn, Mg, Cu, and Al on their salts? What is the order of their reactivity in such reactions?
- ACTIVITY 10.3.4 Do ionic compounds dissolve in both polar and non-polar solvents?
- ACTIVITY 10.3.5 Do ionic compounds conduct electricity?
- ACTIVITY 10.3.6 Do moisture and air affect corrosion?

**10.4 Carbon and Its Compounds****125-131**

- ACTIVITY 10.4.1 How will you study the following properties of ethanoic acid (1) odour (2) solubility in water (3) effect on litmus (4) reaction with sodium bicarbonate.
- ACTIVITY 10.4.2 How do ethanol and ethanoic acid react with each other in the presence of conc.  $\text{H}_2\text{SO}_4$ ?
- ACTIVITY 10.4.3 What happens when alkaline solution of potassium permanganate is added to alcohol?
- ACTIVITY 10.4.4 How will you test hard water by using soap and detergent solution?
- ACTIVITY 10.4.5 How will you compare the foaming capacity of soap in hard water and distilled water?

<b>10.5 Life Process</b>	<b>132-142</b>
ACTIVITY 10.5.1	How to study stomata?
ACTIVITY 10.5.2	How to demonstrate the role of light in photosynthesis?
ACTIVITY 10.5.3	How to demonstrate importance of carbondioxide in photosynthesis?
ACTIVITY 10.5.4(a)	How to demonstrate liberation of carbondioxide gas during respiration in human beings?
ACTIVITY 10.5.4(b)	How to demonstrate liberation of carbondioxide gas during respiration in plants?
ACTIVITY 10.5.5	How to demonstrate the production of CO <sub>2</sub> during anaerobic respiration?
ACTIVITY 10.5.6	How to observe the effect of salivary amylase on food?
ACTIVITY 10.5.7	How to demonstrate the process of absorption (imbibition)?
<b>10.6 Control and Coordination</b>	<b>143-144</b>
ACTIVITY 10.6.1(a)	How to demonstrate phototropism in plants?
ACTIVITY 10.6.1(b)	How to demonstrate geotropism in plants?
<b>10.7 How do Organisms Reproduce</b>	<b>145-148</b>
ACTIVITY 10.7.1	How to observe organisms multiplying by asexual reproduction?
ACTIVITY 10.7.2	How do some plants propagate vegetatively?
ACTIVITY 10.7.3	How to study different parts of flower and their role in sexual reproduction.
<b>10.8 Heredity and Evolution</b>	<b>149-151</b>
ACTIVITY 10.8.1	How to compare homologous and analogous organs in plants and animals?
ACTIVITY 10.8.2	How to study distribution of hereditary characters?
<b>10.9 Reflection and Refraction</b>	<b>152-164</b>
ACTIVITY 10.9.1	How do we observe the image formed by (i) concave (ii) convex reflecting surfaces?
ACTIVITY 10.9.2	What happens when sun rays are focussed by a concave mirror on a piece of paper?
ACTIVITY 10.9.3	How can the image of a lighted candle formed by concave mirror be studied?
ACTIVITY 10.9.4	How can the characteristics of the image formed by a convex mirror be studied?
ACTIVITY 10.9.5	How can the image of an object formed in a plane mirror be studied?



- ACTIVITY 10.9.6 How can refraction of light through a rectangular glass slab be studied?
- ACTIVITY 10.9.7 What happens when Sun rays are focussed by a convex lens on a piece of paper?
- ACTIVITY 10.9.8 How can the nature of the images of a lighted candle, be studied by convex lens?

**10.10 Electricity****165-174**

- ACTIVITY 10.10.1 Do components made of different materials offer different electrical resistance?
- ACTIVITY 10.10.2 What are the factors on which the resistance of a metallic conductor depends?
- ACTIVITY 10.10.3 Is the current passing through different points same in an electric circuit consisting of different resistors connected in series?
- ACTIVITY 10.10.4 Does the potential difference across different resistors connected in series in an electric circuit depend upon the value of a resistor?
- ACTIVITY 10.10.5 Whether the potential difference across the ends of different resistors connected in a parallel combination are the same? Is the current flowing through them are the same?

**10.11 Magnetic Effects of Electric Current****175-187**

- ACTIVITY 10.11.1 Does a current carrying conductor produce magnetic field?
- ACTIVITY 10.11.2 What is the pattern of magnetic field lines around a bar magnet?
- ACTIVITY 10.11.3 How to draw magnetic field lines around a bar magnet?
- ACTIVITY 10.11.4 How does a current carrying circular coil produce a magnetic field?
- ACTIVITY 10.11.5 How does a conductor placed in a magnetic field behave when a current is passed through it?
- ACTIVITY 10.11.6 What happens when a magnet is moved near a coil of wire?
- ACTIVITY 10.11.7 What is the effect of varying the current in a coil on placing another coil near it?

## NCERT SECONDARY SCIENCE KIT

### I. ABOUT THE KIT AND ITS MANUAL

The *NCERT Secondary Science Kit* with its manual provides various learner-centred activities on the various chapters of science textbooks for Classes IX and X based on the new syllabus developed by the NCERT. The activities included in this manual also fully cover the practicals prescribed by CBSE for Classes IX and X. The Kit contains scientific and general items, chemicals, glassware, tools, etc. Attempts have been made to make the items

- Low cost
- Multipurpose
- Microscaler

Some of the outstanding examples are W-tube, laboratory stand-cum-wise, compound and dissecting microscopes, bell-jar for electrolysis, electroscope, lung apparatus, kerosene burner, slides, coils, optics kit, spring balance, etc. There has been special provision for use of microscale chemistry lab techniques which reduces, hazards and wastage of chemicals and provides pollution free atmosphere.

Most of the activities described in the manual can be performed by using items in the kit. However, some activities may require few additional items and which are easily available from the surroundings. These activities/practicals are meant to encourage the students to explore science concepts through their observations and to understand these concepts through various activities/experiments. In order to link the contents of the manuals with the contents of the textbooks, the names of the corresponding chapters of the textbooks have been mentioned. Each chapter has problem oriented topics (in an interrogative form). In case, the teachers/students feel interested in additional activities, they are at liberty to do so by performing the extension activities.

In order to guide your activities, structured performing steps are suggested to facilitate the sequential development of the concepts. Motivational questions on the activities are also suggested. Wherever required, the clues for answer to some

questions are given. Materials required to perform the activity are also suggested.

The attraction of putting together a set of teaching-learning aids/ apparatus in a portable container along with the manuals has given boost to this development of science kit programme. The science kit is, thus, an essential alternative to the lack of any equipment in most of the schools in India and is a supplement to the textbooks. The kit has the following advantages:

- Availability of necessary pieces of apparatus/items at one place.
- Multipurpose use of each piece of apparatus.
- Economy of time in setting up of experiments.
- Portability from one place to another.
- Provision for teacher's innovation.
- Low cost and use of indigenous resources.

The use of science kits has been highly recommended in National Curriculum Framework (NCF), 2005, for effective learning through "hands-on minds-on" learning approaches.

## **2. SCIENCE LEARNING APPROACH - "HANDS-ON MINDS-ON" LEARNING**

There has been a rapid expansion of scientific knowledge in recent years. Realisation of the relevance of science education as reflected in human thought, style, social values and culture have made it imperative to upgrade the curriculum and learning approaches of science in order to improve the quality of life. To develop and transform a learner into a scientifically literate citizen and as envisaged in the National Policy on Education, 1986 and NCF, 2005, there is an imperative need for the learner to:

- Understand and apply the basic concepts of science;
- Learn scientific enquiry skills of gathering information;
- Develop desirable attitudes and value appreciation for truth and objectivity.
- Learn scientific method and apply it in solving problems and taking decisions to improve everyday living and environmental conditions and to promote development and use of technology.

For achieving these objectives, it is necessary to shift emphasis from rote- memory based, content oriented and teacher-centred method of teaching to "hands-on minds-on" learning approaches like:

- Problem solving-based;
  - Activity oriented;
  - Performance-based; and
  - Learner-centred approaches.
- These approaches would require learner to:
- Investigate;
  - Develop observation skills;
  - Record observations;
  - Structure, organise and communicate information;
  - Hypothesise;
  - Collect and analyse data;
  - Draw relevant inferences;
  - Design solutions and act accordingly.

These approaches provide plenty of opportunity for thinking, reasoning and looking at science in its totality as a highly rational, intellectual problem-solving human activity. However, to make the best use of the learning situations, it is very essential that the teacher is provided with effective learning materials in addition to the textbooks. Textbooks alone cannot provide the right learning material. Unfortunately, teaching of science in India has been textbook-centred. We are attempting to change this scenario through developing various types of science kits programmes. Secondary Science Kit is one of them.

### **3. HOW DOES A “HANDS-ON MINDS-ON” SCIENCE APPROACH THROUGH SCIENCE KITS FIT INTO A TEXTBOOK-CENTRED SCIENCE PROGRAMME?**

The science textbook serves as a springboard for instructions and learning. “Hands-on minds-on” learning activities through science kits are used to reinforce and extend what the students have learnt by reading the text and what they have learned through class discussions. At the completion of a chapter or unit, these activities are useful in helping students to establish the relationship of concepts and synthesise their knowledge. The teaching of lab skills, problem-solving strategies and group learning skills can be easily incorporated into the learning activity through the kits.

Teachers depending solely upon textbooks often wonder why their students lack the motivation to learn, as well as why their students often have difficulty learning facts. Teachers who provide appropriate materials for children to interact within the above-mentioned approach find their students have a much higher level of motivation and understanding.



#### **4. HOW TO MAKE LEARNING EFFECTIVE USING THE KITS**



“Hands-on Minds-on” science activities should be used in at least three different ways, if used in conjunction with a textbook programme. Firstly, materials should be supplied to students before they begin a new topic. Students should be given the opportunity to explore freely activities and materials to generate interests and prompt questions related to topic. Secondly, hands-on activities should be used to enable students to observe phenomena that are presented in their textbooks. Finally, students should be given an opportunity to design new experiments based on the knowledge they have acquired. Based on the above pedagogy, kits along with detailed manuals have been prepared to instruct the users how to use materials and to explore the concepts through activities which combines textbook activities with aspects of “hands-on minds-on” learning.



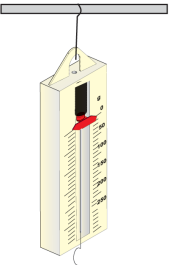

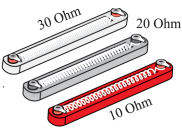
It is preferable for the students to perform all the activities individually or in small groups. In view of the limited number of the items provided in the kits, sometimes teacher may have to conduct experiment/demonstration on some topics for the whole class. Teacher should involve the students in understanding various steps of the activity/demonstration. The proper learning situation facilitates personal investigation/small group activity to conduct the investigation for presentation of results and useful discussions. This may also help in carrying out project work by the students.

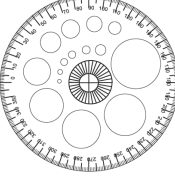
If an activity does not succeed, one should not get discouraged. In such a situation the teacher along with student should, try to analyse why the activity has not succeeded. A number of ideas may come up for successful performance of the activity. The most reasonable suggestion may then be tried out. If it still does not help, another idea can be tried out till the activity succeeds. By repeating the steps and controlling the procedure during an activity as a method of discovery, the learner is able to understand the whole process more closely, like a budding scientist discovering new ideas or an engineer inventing new solutions to problems or an artist creating new designs.

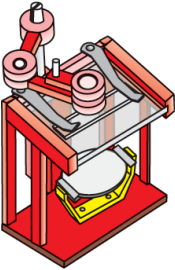

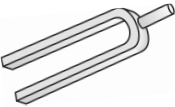
## LIST OF SECONDARY SCIENCE KIT ITEMS



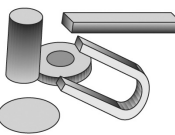
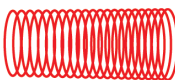

<b>GENERAL ITEMS (Category - A)</b>			
<b>S. No.</b>	<b>Item Name (Quantity)</b>	<b>Figure/Setup</b>	<b>Uses</b>
1.	Spring balance  (1)		<ul style="list-style-type: none"> <li>- To measure weight up to 250g wt. (newton)</li> <li>- To measure the force of pull applied for pulling object on plain/rough surfaces</li> <li>- To show the ease in pulling object on plain/rough surfaces</li> <li>- To introduce the concept of density of different metals</li> </ul>
2.	Magnetic compass  (1)		<ul style="list-style-type: none"> <li>- To show North and South direction</li> <li>- To show effect of N.S. pole on magnetic compass</li> </ul>
3.	Set of four resistors.  10 ohm. (1) 20 ohm (2) 30 ohm. (1)		<ul style="list-style-type: none"> <li>- To show resistances in series and parallel</li> <li>- To study Ohm's law</li> </ul>

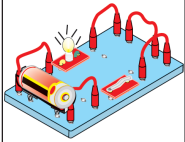

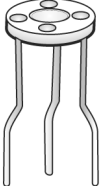
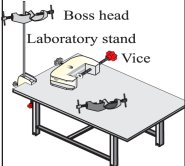
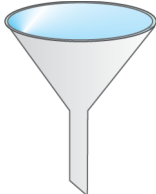

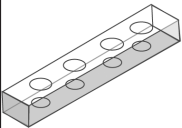
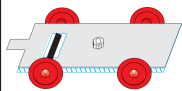

S. No.	Item Name (Quantity)	Figure/Setup	Uses
4.	Protractor Full circle (1)		<ul style="list-style-type: none"> <li>- To draw and measure angles</li> </ul>
5.	Graduated syringe (2 mL) (1)		<ul style="list-style-type: none"> <li>- As a measure of liquids 2mL</li> <li>- To transfer liquids during experiments</li> </ul>
6.	Compound Microscope (1)		<ul style="list-style-type: none"> <li>- For assisting eyes in seeing minute</li> <li>- Objects or features of objects which can't be seen with the naked eye</li> <li>- To observe slides, features of insects</li> </ul>
7.	Dissecting Microscope (1)		<ul style="list-style-type: none"> <li>- Organisms - Used for viewing the dissected</li> <li>- Used for examining samples of soil, thread, yarn, insects etc</li> </ul>

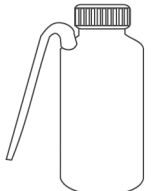



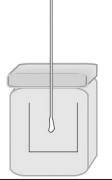

S. No.	Item Name (Quantity)	Figure/Setup	Uses
8.	Tuning fork (1)		- To show that sound is produced by vibrating objects
9.	Measuring cylinder (1)		- To measure volume of liquids during experiments - As a container
10.	Pasteur Pipette (4)		- General use for transferring of liquids - Electrolysis of water for collecting gases
11.	Syringe Pump (1)		To study the force of reaction
12.	Magnet -Disc magnet (ferite) (dia 45 mm, thickness 10 mm) (1) -Bar magnet (alnico) (5cm×1cm × 0.8cm) (2) -Horse shoe magnet (5 cm × 1.5 cm) (1) - Cylindrical magnet (dia 1 cm × 2 cm)		- To show that the attraction for iron is intense at end but poor at middle - To show existence of poles - To show freely suspended magnets always point N-S direction - To show attraction of opposite poles and repulsion of similar poles - To show existence of magnetic field
13.	Slinky (1)		- To show longitudinal and transverse waves

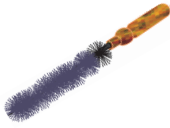

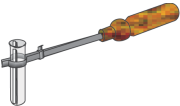

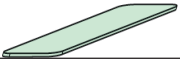

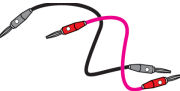



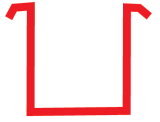

S. No.	Item Name (Quantity)	Figure/Setup	Uses
14.	Circuit Board assembly with Torch bulb 1.5V Qty 1 No.		<ul style="list-style-type: none"> <li>- To illustrate essential components of simple circuit.</li> <li>- To show make and break of circuit.</li> <li>- To show how electricity can be used to do work.</li> <li>- To show electromagnet.</li> </ul>
15.	Kerosene burner Qty. 1 No.		<ul style="list-style-type: none"> <li>- Used as heat source in various experiments.</li> <li>- To understand principle of wick/chimney as alternate to gas burner.</li> </ul>
16.	Tripod Stand Qty. 1 No.		<ul style="list-style-type: none"> <li>- Used as stand for various experiments including heating liquids in beaker.</li> </ul>
17.	Laboratory Stand Plastic Vice and Boss head and clamp Qty. 1 each		<ul style="list-style-type: none"> <li>- A collapsible stand / arrangement for performing various experiments.</li> </ul>
18.	Plastic funnel Qty. 1 No.		<ul style="list-style-type: none"> <li>- For pouring liquids into container.</li> <li>- To show filtration.</li> </ul>

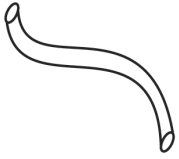

S. No.	Item Name (Quantity)	Figure/Setup	Uses
19.	Stainless Steel electrodes with cork 1 each		- To study the conductivity of the ionic compound solution, electrolysis of water, etc
20.	B.P. and M.P. Apparatus (1)		- Aluminium block used to determine the boiling point of water and melting point of solids
21.	Test Tube Stand (4)		- To hold test tubes while reactions happen in them or while they are not needed
22.	Trolley (2)		- Used for studying the force of friction
23.	China dish (1)		- Heating of chemical during experiment - As container
24.	Wash bottle (1)		- For contain water to wash the apparatus

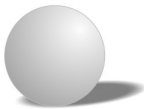
<b>GENERAL ITEMS (Category - B)</b>			
<b>S. No.</b>	<b>Item Name (Quantity)</b>	<b>Figure/Setup</b>	<b>Uses</b>
1.	Rubber bands (assorted size) (10)		- Miscellaneous use
2.	Rubber balloons (assorted size) (10)		- To show that sound can travel in water - Used as diaphragm in experiment to show inspiration and expiration - Miscellaneous use
3.	Calorimeter (1)		LPPE foam container in which 50 mL beaker is placed Used for thermochemical experiment
4.	Forceps (1)		- For picking and holding the objects while experimenting
5.	Rubber corks (1)		- Miscellaneous use
6.	Cell Holder (2)		- For holding 1.5 V dry cells
7.	Test tube brush (1)		- For cleaning glasswares

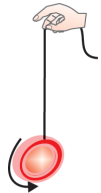
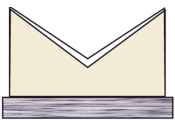
S. No.	Item Name (Quantity)	Figure/Setup	Uses
8.	Test Tube Holder (1)		- To hold test tube while performing (experiments) - Heating chemicals during experiments
9.	Plane mirror strips (3)		- For preparing Kaleidoscope
10.	Copper strip (4)		- Cu as electrodes for electrolysis
11.	Zn Strip (4)		- As a electrode
12.	Iron strip (4)		- To differentiate materials on the basis of the colour, strength etc
13.	Sand paper of different numbers (each)		General use
14.	Connecting wire banana plugs		- As connectors during various electrical experiment
15.	Transparent stiff plastic tube (1)		- To show that in uniform motion distance covered in equal time interval
16.	Dropper (2)		- To transfer drops of chemicals



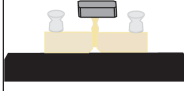
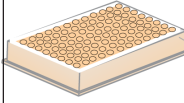

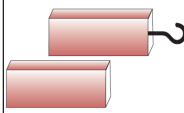
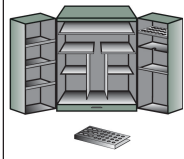
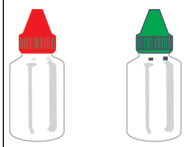
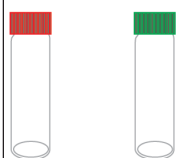
S. No.	Item Name (Quantity)	Figure/Setup	Uses
17.	Copper Wire bent in U-form (1)		- To show the force experienced by it when placed in a magnetic field
18.	Constantan Wire (50 cm)		- To study electrical resistance
19.	Copper Wire (50 cm)		- To study electrical resistance
20.	Nichrome Wire (50 cm)		- To study electrical resistance
21.	Transparent PVC tubing (50 cm)		- General use
22.	Filter paper (10 Nos.)		- Used for filtering the substances or product of a chemical reaction or in chromatography, etc.
23.	Circular Coil (1)		- Used for showing the magnetic field and mutual induction

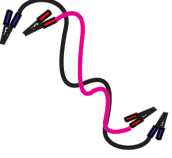
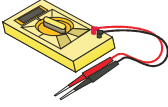

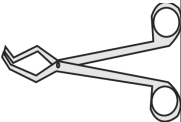

S. No.	Item Name (Quantity)	Figure/Setup	Uses
24.	Steel ball (1)		<ul style="list-style-type: none"> <li>- To show experiments on friction (rolling)</li> <li>- To show oscillating motion</li> <li>- To show time period of simple pendulum</li> </ul>
25.	Pith/Plastic ball		<ul style="list-style-type: none"> <li>- Used for general purpose</li> </ul>
26.	Yo-Yo (1)		<ul style="list-style-type: none"> <li>- To show transfer of energy</li> </ul>
27.	Mirror/lens stand (1)		<ul style="list-style-type: none"> <li>- For holding the lens and spherical mirror</li> </ul>
28.	Spatula (1)		<ul style="list-style-type: none"> <li>- For transferring the solid chemicals</li> </ul>
29.	Wooden Ice Cream spoon (1)		<ul style="list-style-type: none"> <li>- Used for general purpose</li> </ul>

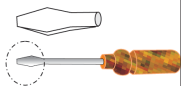

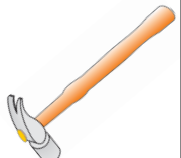

S. No.	Item Name (Quantity)	Figure/Setup	Uses
30.	Plug Key (1)		- Used as switch in the electrical circuit
31.	Well Plate (1)		- Used as stand for keeping chemicals in small bottles
32.	Blotting Paper (1)		- General use
33.	Wooden Block (1)		- General use
34.	Kit Box (1)		- Used for keeping all the kit items
35.	Dispensing bottles (30)		- For Keeping the chemical reagents
36.	Vials (20)		- For storing the solid chemicals

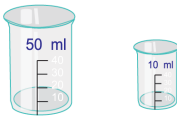

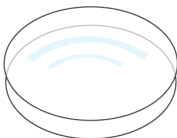

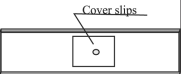
S. No.	Item Name (Quantity)	Figure/Setup	Uses
37.	Crocodile Clips (5 sets )		- Used as connectors during various electrical experiments
38.	Multimetre (1 set)		- Electrical experiments

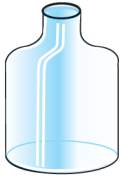

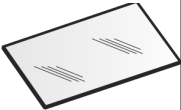
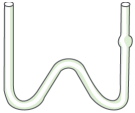
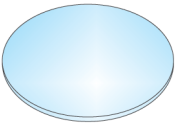
<b>TOOLS ITEM</b>			
<b>S. No.</b>	<b>Item Name (Quantity)</b>	<b>Figure/Setup</b>	<b>Uses</b>
1.	Pair of tongs (1)		- For holding glass rod, test tube etc. during experiments
2.	Surgical Scissor (1)		- Used for cutting thin metal/ plastic foil - For pruning plants etc
3.	Screw driver (1)		- Used for screwing /unscrewing
4.	Dissecting Needles (2)		- To point out different parts of biological specimen - To pierce paper or any other such item
5.	Claw hammer (1)		- To remove inserted nails - For inserting nails in table/wall - For breaking solid chemical - To feel hardness/softness of metal - To show simple lever

<b>GLASS APPARATUS AND MATERIALS</b>			
<b>S. No.</b>	<b>Item Name (Quantity)</b>	<b>Figure/Setup</b>	<b>Uses</b>
1.	Capillary tube 1 box		- For boiling point determination
2.	Micro test tube 4 mL (16 Nos)		- For experiments requiring heating, holding of chemical etc.
3.	Magnifying glass (1 No)		- Used to show magnification - To study structure of various chemical, granules etc.
4.	Beakers 10mL(4) 50 mL (1)		- As container for use in electro-chemical experiments, thermo-chemistry, preparation of salts, etc.
5.	Slide (5 Nos)		- For keeping the specimen to view under the microscope.
6.	Plastic Petridish (1 No)		- As container

S. No.	Item Name (Quantity)	Figure/Setup	Uses
7.	Cover slips (20 Nos)		- For covering specimen that is being observed under a microscope
8.	Glass Rod (1 No)		- As stirrer for hot and cold liquids.
9.	Bell Jar (1 No)		- To show function of lungs - Distillation of water with solar energy - To show electrolysis.
10.	Double mouthed flask (1 No)		- To show percentage of oxygen in air - To show acidic and basic character of non-metals
11.	Glass tube (1 No)		- For miscellaneous use in chemistry experiment
12.	Glazed glass plate (1 No)		- To mix chemicals (dry or paste type) during experiments
13.	W-tube (4 Nos)		- To test properties of gases
14.	Watch glass (1 No)		- To hold solids when being weighed or transported

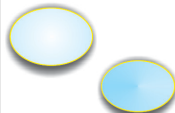
S. No.	Item Name (Quantity)	Figure/Setup	Uses
15.	Stirrer (1)		- Used for stirring in the calorimeter
16.	Measuring flask (1)		- To prepare the exact volume of liquids
17.	Conical flask		- Used for titration
18.	Ignition tube (10)		- For boiling point determination
19.	Blade (1)		- For cutting wax, semisolid chemical, pruning of plants etc
20.	Concave and Convex Lens (FL 20 cm, dia 50 mm) (1 each)		- Used to show the image formation on a screen

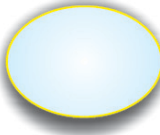
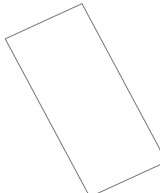
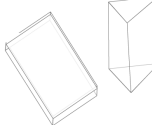
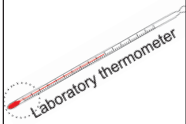
S. No.	Item Name (Quantity)	Figure/Setup	Uses
21.	Concave and Convex mirror FL 20 cm, dia 50 mm (1 each)		- Used to show the image formation on a screen
22.	Plane mirror (dia 50 mm) (1)		- Used to the image formation
23.	(a) Glass slab (b) Glass triangular prism (1 each)		- To study refraction of light through slab and prism
24.	Thermometer Laboratory (0° to 250°) (1)		- For measuring temperature of hot and cold liquids, soil, water etc

## LIST OF CHEMICALS, METALS AND REAGENTS

S.No.	Name of chemicals, metals and reagents
1.	Acetic acid
2.	Aluminium sulphate
3.	Ammonium chloride
4.	Ammonium hydroxide
5.	Barium chloride
6.	Blue and red litmus paper
7.	Calcium oxide
8.	Copper oxide
9.	Copper powder
10.	Copper sulphate
11.	Copper turnings
12.	Dil. H <sub>2</sub> SO <sub>4</sub>
13.	Dil. Hydrochloric acid
14.	Fine iron dust
15.	Glycerine
16.	Iodine solution
17.	Iron sulphate
18.	Lead nitrate
19.	Manganese dioxide
20.	Magnesium sulphate
21.	Methyl orange
22.	Methylene blue
23.	Naphthlene

<b>S.No</b>	<b>Name of chemicals, metals and reagents</b>
24.	Permanent slide
	i. Nerve fibres
	ii. Spirogyra
	iii. Striated muscles
	iv. Amoeba
	v. Hydra
25.	Phenolphthalein
26.	Potassium hydroxide
27.	Potassium permanganate
28.	Potassium dichromate
29.	Potassium iodide
30.	Rectified spirit
31.	Safranin
32.	Sodium chloride
33.	Sodium hydroxide
34.	Sodium bicarbonate
35.	Sulphur powder
36.	Silver nitrate
37.	Starch powder
38.	Sodium sulphate
39.	Universal indicator solution/pH paper
40.	Yeast
41.	Zinc sulphate

**ACTIVITIES**  
**CLASS IX**  
**9.1 Matter in Our Surroundings**

**ACTIVITY 9.1.1 How will you show and compare the compressibility of gases and liquids?**

**What is required?**

Syringe (2mL), water and beaker

**How will you proceed?**

1. Take a clean syringe and pull the piston outward [Fig. 9.1.1 (a) i].
2. Block the nozzle of the syringe with your thumb [Fig. 9.1.1 (a) ii] and push the piston inward. Release the piston and record its position.
3. Push the piston inward again and release it. Does it come back to its original position? [Fig.9.1.1 (a) iii]
4. Repeat the above experiment by filling the syringe with water and note the observations [Fig.9.1.1 (b)].

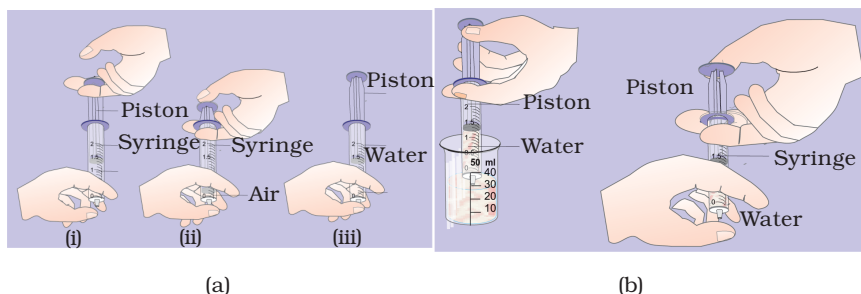

**Fig. 9.1.1(a)** Syringe with air **(b)** Syringe with water

**What have you learnt?**

1. In case of air/gases, the piston could be pushed to some distance. In case of water, the piston did not move.
2. The above activity proves that gases are compressible whereas liquids are not or less compressible in comparison to air/gases.



**ACTIVITY 9.1.2 How will you determine the boiling point of water and melting point of ice?****Part A**

Determination of boiling point of water.

**What is required?**

Fusion tube, capillary tube, tripod, kerosene burner, thermometer, aluminium block, Pasteur pipette and stand with clamp

**How will you proceed?**

1. In a fusion tube, transfer 4-5 drops of water with the help of Pasteur pipette and place it in one of the holes of the aluminium block (B.P. and M.P. apparatus). Care should be taken such that water level in the fusion tube is visible after placing it in the hole. Seal one end of a capillary tube in the flame of the kerosene burner. Dip the open end of the capillary tube into water in the fusion tube.
2. Insert the thermometer in the second hole of the aluminium block.
3. Put the aluminium block on the tripod stand and heat the apparatus with the help of kerosene burner slowly.
4. Observe what happens to water. Do you see any bubbles arising slowly in the fusion tube?
5. Record the temperature when you observe a steady stream of bubbles. This temperature is the boiling point of water. Do you observe any further rise in temperature after the steady stream of bubbles started coming out?

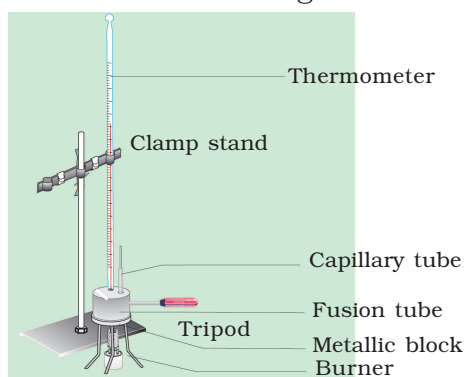

**Fig. 9.1.2(a)** Determination of boiling point of water

**What have you learnt?**

1. Boiling point of water is remains constant during the boiling of water.

**Part B**

Determination of melting point of ice.

**What is required?**

Micro beaker (10 mL), stand with clamp, thermometer, cork and ice

**How will you proceed?**

1. Take crushed ice in a micro beaker and insert a thermometer in the beaker by hanging it from the clamp of the stand in such a way that the bulb of the thermometer is completely inside the ice.
2. Wait for some time and keep recording the temperature after small intervals of time.
3. Note down the temperature when ice just starts melting.
4. Let the bulb of the thermometer remain in mixture of ice and water for some more time and keep recording the temperature. Do you observe further change in temperature?

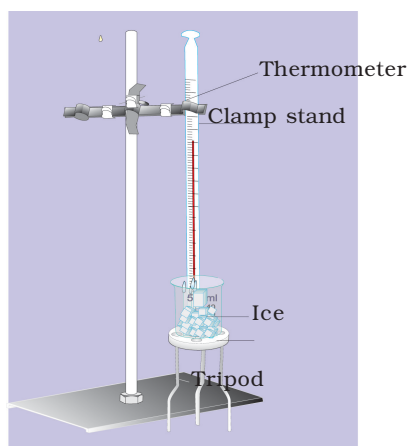

**Fig.9.1.2 (b)** Determination of melting point of ice

**What have you learnt?**

1. The melting point of ice is remains constant during melting of the ice.

**ACTIVITY 9.1.3 How will you study the phenomenon of sublimation?****What is required?**

Camphor / naphthalene / iodine, tripod, China dish, funnel, cotton, kerosene burner and spatula

**How will you proceed?**

1. Take a spatula full of crushed camphor / naphthalene / iodine in a clean and dry China dish and place it on the tripod.

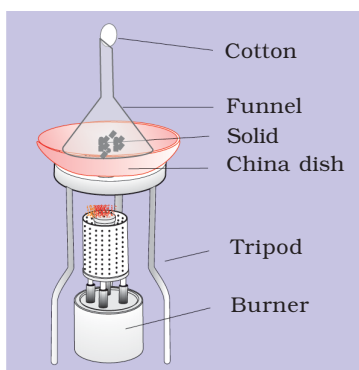

**Fig. 9.1.3** Sublimation of solids

2. Take a funnel and plug its nozzle with of cotton.
3. Invert this funnel on the China dish.
4. Light the kerosene burner and place it under tripod.
5. Heat the China dish for a few minutes and observe what happens.
6. Has a camphor / naphthalene / iodine change into the liquid state?

**What have you learnt?**

1. On the inner wall of the funnel, solid deposit of camphor/ naphthalene/iodine was observed.
2. Solid camphor / naphthalene / iodine on heating changed from solid state directly to vapour state. This process is known as sublimation.

**ACTIVITY 9.1.4 How does the rate of evaporation of different liquids differ?****What is required?**

Water, acetone, rectified spirit, micro beakers (10 mL) and thermometer

**How will you proceed?**

1. Take 5 mL each of water, acetone and rectified spirit in three micro beakers, respectively.
2. Record the temperature of each of the three liquids.

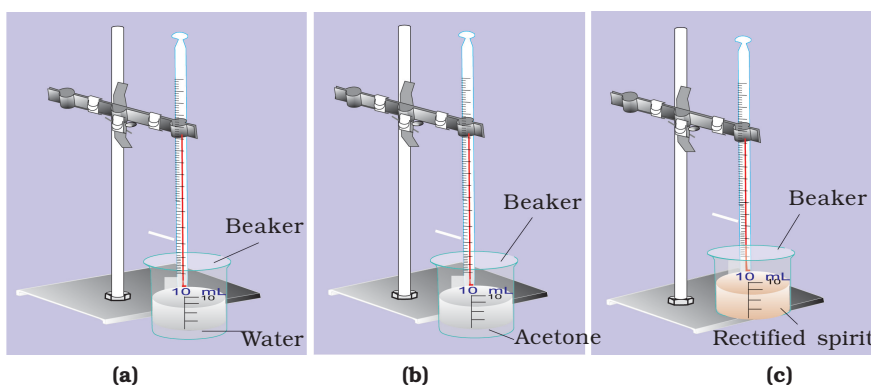

**Fig. 9.1.4** Evaporation of (a) Water (b) Acetone (c) Rectified spirit

3. Wait for about 10 minutes and again record the temperature of each liquid. Do you find any change in the temperatures of these three liquids?
4. Measure the volume of each liquid remaining in the beaker.
5. Note the decrease in volume of each liquid.
6. Repeat the above activity by keeping the above set-up in direct sunlight and observe. What happens to the rate of evaporation with the increase in temperature?

**What have you learnt?**

1. Order of rates of evaporation for water, acetone, rectified spirit is acetone > rectified spirit > water.
2. Rate of evaporation increases with the increase in temperature and decreases with the decrease in temperature.

## 9.2 Is Matter Around Us Pure?

### ACTIVITY 9.2.1 How to prepare the saturated solution of common salt in distilled water?

#### What is required?

Common salt (sodium chloride), water, micro beaker (10 mL), glass rod, kerosene burner and tripod

#### How will you proceed?

1. Take 5 mL of distilled water in a micro beaker.
2. Add one spatula full of sodium chloride to the beaker and stir it with the help of a glass rod.
3. Keep on adding one spatula of salt at a time to the beaker and dissolving it till no more sodium chloride dissolves. The solution thus obtained is the saturated solution of sodium chloride.
4. Repeat this activity taking 5 mL of hot water in the beaker and count that how many spatulas of the salt has dissolved.

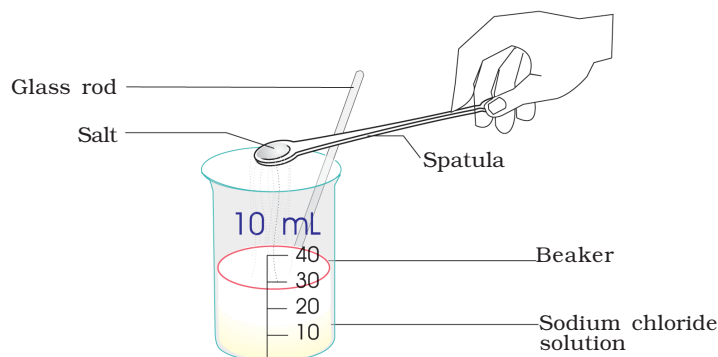

**Fig.9.2.1** Preparation of saturated solution of common salt

#### What have you learnt?

1. The solution in which no more solute dissolves at a particular temperature is called saturated solution.
2. The solubility increases as the temperature increases.

**ACTIVITY 9.2.2 How to prepare a solution of common salt of 10 per cent composition by volume?****What is required?**

Sodium chloride, distilled water, measuring flask (25 mL), physical balance, watch glass and spatula

**How will you proceed?**

1. Take 2.5 g sodium chloride.
2. Transfer it to 25 mL measuring flask.
3. Add some water and shake it well to completely dissolve the sodium chloride in water.
4. Add water to the flask up to the mark of flask. This is 10% concentration by volume of a solution.

Note: Use the physical balance available in the school laboratory.

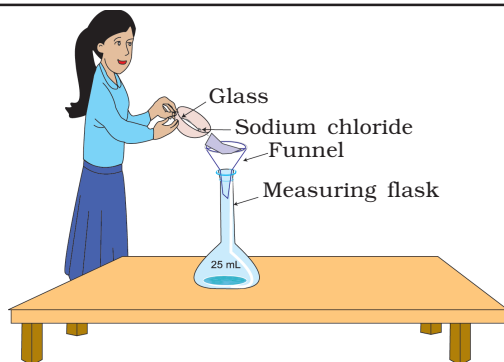

**Fig. 9.2.2** Preparation of solution of common salt of 10% composition by volume

**What have you learnt?**

1. In 10% solution of sodium chloride in water by volume, the solute is 10 g and the solvent is 100 mL.

### ACTIVITY 9.2.3 How to separate the components of a mixture containing sand, common salt and camphor?

Note: You may be given ammonium chloride instead of camphor, but it is difficult to separate it completely).

#### What is required?

China dish, funnel, tripod stand, beaker, kerosene burner, water, filter paper, glass rod, mixture of sand, common salt and camphor, cotton and stand with clamp

#### How to proceed?

1. Take the mixture in a China dish and cover it with a cotton plugged inverted funnel as was done in Activity 9.1.3.
2. Heat the contents of the China dish till the whole of camphor sublimes.
3. Remove the funnel and collect the solid deposited on the inner side of the funnel by scrapping it.

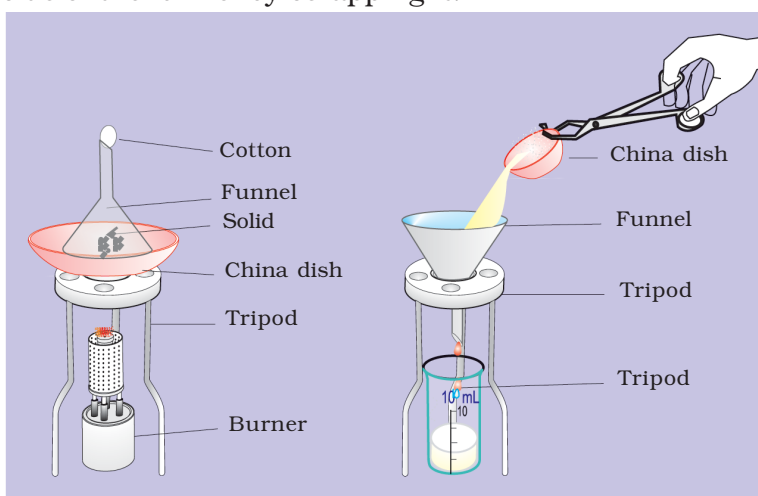

**Fig. 9.2.3** Separation of a mixture of sand, common salt and camphor

4. Now add water to the China dish after cooling. Stir well.
5. Fold the filter paper and fit it in the funnel. Transfer the contents of the China dish to the funnel.
6. Collect the filtrate in a beaker and evaporate water from the solution to get back common salt.
7. You will get the sand on the filter paper.

**What have you learnt?**

1. Camphor can be separated from the mixture by sublimation.
2. Sand can be separated from the dissolved common salt by filtration.
3. Common salt can be obtained by evaporation from its solution in water.
4. A solute when dissolved in the solvent does not lose its properties.



**ACTIVITY 9.2.4 How to prepare and identify a homogenous mixture and a heterogeneous mixture?****What is required?**

Sodium chloride/sugar, sand/chalk powder, water, micro beaker, stirring rod, funnel, filter paper, tripod, starch powder and kerosene burner

**How to proceed?****Part A**

*How to prepare a homogenous mixture (solution)?*

1. Take 5 mL of water in a 10 mL micro beaker and add one spatula full of sodium chloride/ sugar to it.
2. Stir it well and filter.
3. What do you observe on the filter paper?
4. Do you observe any particles settling down in the solution?

**Part B**

*How to prepare a suspension?*

1. Take 5 mL of water in a micro beaker and add one spatula of sand/chalk powder to it.
2. Stir it well and observe carefully.
3. Filter the solution through a filter paper.
4. What do you observe on the filter paper?

**Part C**

*How to prepare a colloidal solution?*

1. Take one spatula of starch powder in a 10 mL micro beaker and make its paste with water.
2. Add the paste gradually by constant stirring to another beaker containing 5 mL water.
3. Heat the mixture with constant stirring. Do not boil.
4. Cool it and filter.
5. What do you observe on the filter paper? Do you observe some turbidity in the filtrate?

In this colloidal solution, you cannot see the particles of starch, whereas you could see the particles of sand in the suspension. The particles in colloids are so small that you cannot see them with naked eyes. But you can prove them to be present when a

beam of light is passed through the solution. These become visible by scattering the light.

Mixture in Part A is homogeneous mixture.

Mixture in Part B and Part C are heterogeneous mixtures

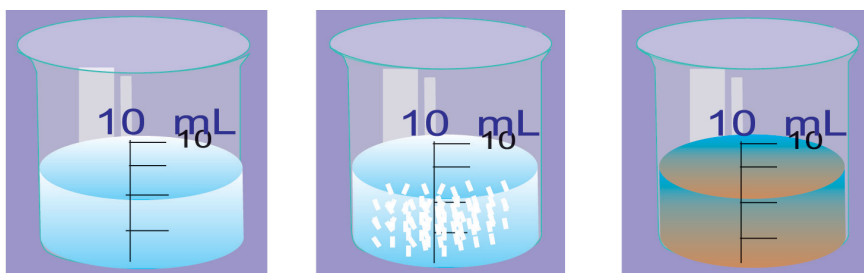

**Fig. 9.2.4**

**(a)** Solution of sodium chloride/sugar in water (Homogenous mixture)

**(b)** Suspension of chalk in water (Heterogenous mixture)

**(c)** Colloidal solution of starch in water (Heterogenous mixture)

### What have you learnt?

1. Salt/sugar in water forms a homogenous mixture.
2. Sand/Chalk powder in water forms a heterogenous mixture.
3. The residue was seen on the filter paper in case of heterogenous mixture.
4. The homogenous solution is transparent.
5. Suspensions are opaque.
6. Suspended solid can be separated by filtration.
7. Colloidal solutions are translucent and make a heterogeneous mixture.
8. Solid particles of a colloidal solution cannot be separated by filtration.
9. The enamel paint is an example of heterogeneous mixture and colloidal solution.

**ACTIVITY 9.2.5 How to differentiate between a homogenous solution, colloidal solution and suspension on the basis of transparency, filtration and Tyndal effect?**

**What is required?**

Salt /Sugar, Sand/Chalk powder, starch powder, beaker, funnel, filter papers, stirring rod, tripod stand and kerosene burner

**How to proceed?**

1. Prepare the solution of salt/ sugar, sand/chalk powder and starch powder in water separately in micro beakers as given in Activity 9.2.4.
2. Put a 'X' mark on three pieces of paper. Keep the beakers undisturbed for sometime on these papers respectively.
3. Observe carefully X mark on the papers from top of the beakers.
4. Record your observations in the table given below. Why did we wait for sometime after preparing the mixture?
5. Filter each of the above three mixtures separately in three different beakers.
6. Observe if residue is obtained or not.
7. Record your observations in the following table.
8. Allow the torch light to pass through the three solutions and observe carefully light.
9. Record your observations in the following table.

**Observation Table**

S.No	Mixture	Clear visibility of the mark		Residue obtained		Visibility of path of light	
		Yes	No	Yes	No	Yes	No
1.	Salt + water						
2.	Starch + water						
3.	Chalk powder + water						

Why does the path of light become visible in colloids?

**What have you learnt?**

Amongst the three mixtures, i.e., salt solution, starch solution and chalk powder suspension.

1. The largest particle size is in case of chalk powder with water solution.
2. Tyndal effect is shown by starch solution.

**ACTIVITY 9.2.6 How to separate a mixture of two immiscible liquids?****What is required?**

Beaker, stand with clamp, double mouthed flask fitted with a glass stopcock at one end and cork

**How to proceed?**

1. Take equal volume of water and oil in a beaker.
2. Transfer the above contents in a double mouthed flask with glass stopper fitted on lower end. Care should be taken that stopcock is closed.
3. Close the mouth of the flask with cork and shake the mixture well.
4. Leave it for some time till two distinct layers are seen.
5. Open the stopcock slowly and carefully and allow the lower layer to flow down into another beaker.
6. Close the stopcock as soon as the lower layer has completely been transferred and the upper layer reaches the stopcock.
7. Collect the liquid forming the upper layer in a separate beaker.

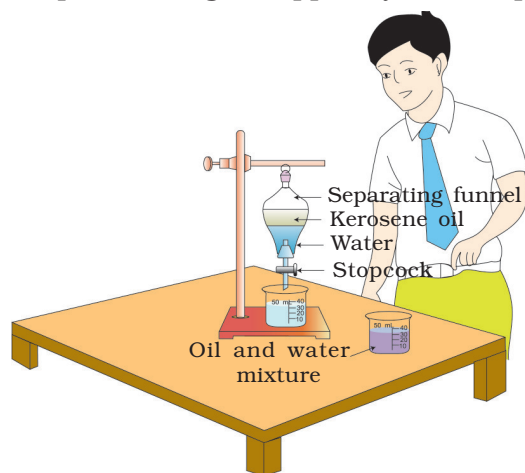

**Fig.9.2.6** Separation of a mixture of oil and water

**What have you learnt?**

1. Oil forms the upper layer in the mixture water and oil.
2. The liquid forming the lower layer has high density than the liquid in the upper layer.

**ACTIVITY 9.2.7 How to differentiate between a mixture and a compound?****What is required?**

Sulphur powder, iron fillings (fine), micro test tube, tripod stand, ferrite bar magnet, test tubes, dil.  $\text{H}_2\text{SO}_4$ , kerosene burner, petridish, pestle and mortar, Pasteur pipette, lead acetate solution and test tube holder

**How to proceed?**

1. Take about 10 spatula of iron fillings/powder and 7 spatula of sulphur powder.

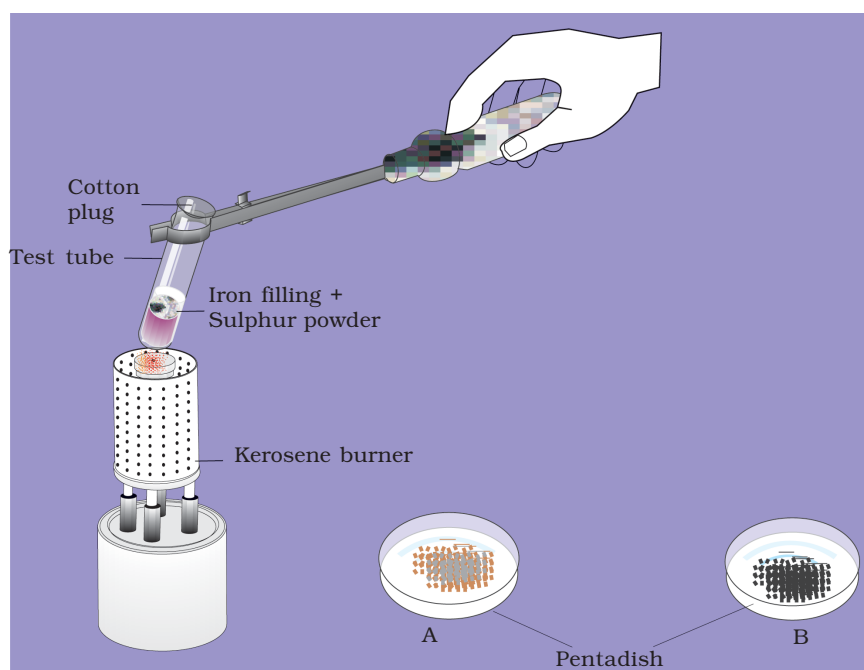

**Fig. 9.2.7 (a)** Iron and sulphide compound formation

**(b)** Iron and sulphur mixture

2. Mix them properly in a China dish.
3. Take half of this above mixture in a micro test tube and put a cotton plug in its mouth. Heat the contents first slowly and then strongly till an incandescent mass is visible in the test tube.

4. Allow the test tube to cool and then scrap out the black mass formed and break it into smaller pieces. Label it as A.
5. Transfer the other half of the mixture (step 2) in a petridish and label it B.
6. Perform the following tests with the samples A and B and record your observations in the following table.

<i>Test</i>	<i>Sample A</i>	<i>Sample B</i>
1. Magnet test: Bring the magnet near each of the samples A and B.	What do you observe? What do you infer? -----	What do you observe? What do you infer? -----
2. Take samples A and B separately in test tubes. (i) Add two drops of dil $\text{H}_2\text{SO}_4$ / $\text{HCl}$ separately to samples A and B (ii) Test the evolved gas as follows: (a) Bring a burning splinter near the mouth of W-tubes. (b) Bring a filter paper dipped in lead acetate solution near the mouth of the test tubes.		
3. Appearance: Place a small quantity of samples A and B on watch glasses. How does it look - (Heterogeneous or Homogenous). Do you see the Fe and S particles?		
4. Behaviour towards $\text{CS}_2$ Take a spatula each of A and B in two separate test tubes. Transfer a few drops of $\text{CS}_2$ to the tubes.		

Note: For test 2 above.  
In case of W-tube, transfer 2-3 drops of lead acetate solution into another arm with the help of Pasteur pipette. Transfer a few drops of dil. $\text{H}_2\text{SO}_4$  into the first arm.

**What have you learnt?**

1. The compounds do not show the properties of its constituents.  
For example 'A' does not show the properties of Fe and S.



## 9.3 Atoms and Molecules

### ACTIVITY 9.3.1 How to verify the law of conservation of mass in a chemical reaction?

#### What is required?

Ignition tube, conical flask, silver nitrate, sodium chloride, thread, cork, balance. (In case silver nitrate is not available due to its high cost, experiment can be done with barium chloride and sodium sulphate)

#### How will you proceed?

1. Prepare 5% solution (mass by volume) of silver nitrate and sodium chloride as mentioned in Activity 9.2.2.
2. Take silver nitrate solution in an ignition tube and sodium chloride solution in the conical flask.

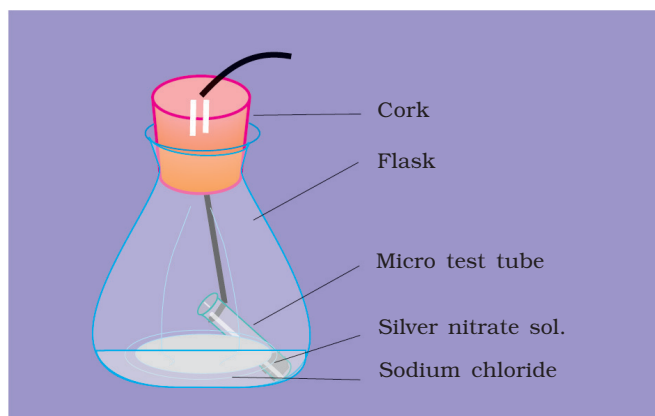

**Fig. 9.3.1** Experiment to show conservation of mass by using sodium chloride solution with silver nitrate solution

3. Hang the ignition tube in the flask with the help of the thread in such a way that the solutions do not get mixed.
4. Fit a cork in the mouth of the flask. Now measure the mass of the flask.
5. After weighing, tilt and swirl the flask so that the two solutions get mixed. Observe the state of the contents carefully.
6. Again determine the mass of the flask. Do you find any difference in the masses in these two cases, one before the reaction and after the reaction?

Note: Use the physical balance available in the school laboratory for preparation of 5% solution (by volume) of silver nitrate and sodium chloride.

**Observations**

Initial mass of the flask and its contents =  $m_1 = \dots\dots\dots$ g.

Final mass of the flask and its contents =  $m_2 = \dots\dots\dots$ g.

**What have you learnt?**

The mass of the reactants and products remains same.

## 9.4 Structure of the Atom

### ACTIVITY 9.4.1 How to build static model of electron distribution in atoms in different orbits of first eighteen atoms?

#### What is required?

Wire, beads, card board, drawing pins and sleeve

#### How will you proceed?

1. Let us build model for Na atom. Fix a drawing pin in the centre of a cardboard. This represents your nucleus of the atom of the element you would like to build model for.
2. Calculate the number of electrons in each orbit of the sodium atom.
3. Make a circular loop of wire with diameter of about 6 cm. Insert two beads and close the ends with the help of sleeve. This is the first orbit. Fix it on the cardboard so that drawing pin is in the centre of this loop.
4. Make another circular loop of diameter of about 10 cm. Insert 8 beads and close the ends. This is the second orbit. Fix this on the cardboard in such a way that the drawing pin is in the centre of this loop also.
5. Make another loop of diameter, say 16 cm. Insert 1 bead and close the ends. This is third orbit. Fix it on the cardboard so that the drawing pin is again at the centre of this loop.

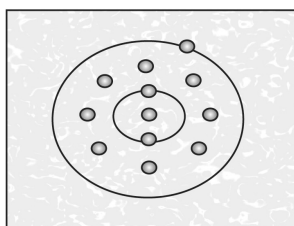

Fig 9.4.1 Model of electron distribution in sodium atom

#### What have you learnt?

A model of sodium atom is built by using wire and beads.

#### Extensions

Build the atomic model of Argon.

## 9.5 The Fundamental Unit of Life

### ACTIVITY 9.5.1(a) How to study the parts of a dissection microscope and their functions?

Dissection microscope is used not only for magnifying objects but also to carry out dissections of small organisms which can not be done by naked eye.

#### What is required?

A dissection microscope

#### How to proceed?

Locate and observe the following parts of the dissection microscope:

1. Base-Holds the body of the microscope.
2. Mirror-Concave on one side and plain on the other.
3. Stage-For keeping the slide or material.

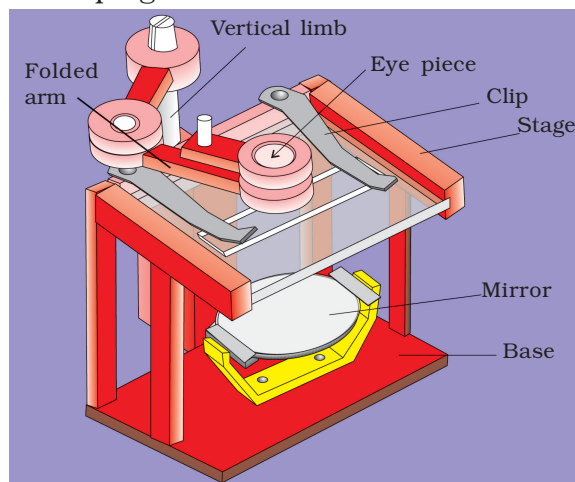

**Fig. 9.5.1(a)** Dissection microscope

4. Clips-To hold the slide in position.
5. Vertical limb-Which can be moved up and down.
6. Adjustment knobs-For focusing.
7. Folded arm-Attached to the tip of the vertical limb, can move the eye piece.
8. Lens holder with lens.

**What have you learnt?**

Dissecting microscope is used to view objects which are too small to be seen by naked eye clearly. This microscope can magnify objects upto 10 or 15 times. Small objects can also be dissected under observation using this device.

**Extension**

Open soaked seeds of moong or urd, and see the plumule and radicle under the dissection microscope.

See small insects like ants and lice, and observe their eyes, limbs and other body parts.

**Precaution**

1. The eye piece and stage should be wiped clean with a moist cloth.
2. Clean the stage of the lens after use.

**ACTIVITY 9.5.1(b) How to study the parts of a compound microscope and their functions?****What is required?**

A compound microscope

**How to proceed?**

Hold the arm of the compound microscope and observe the following parts.

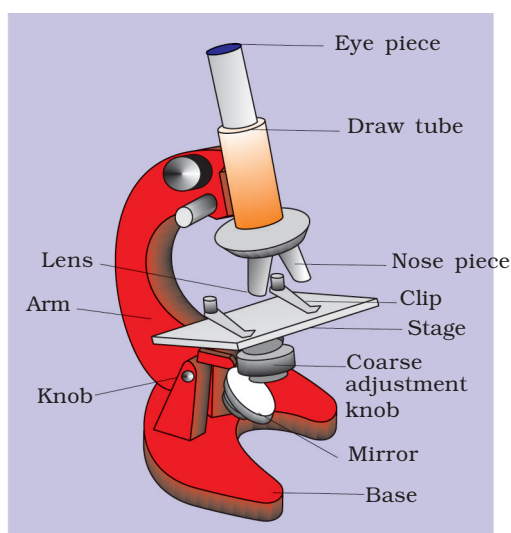

**Fig. 9.5.1(b)** Compound microscope

1. Base—Holds the body of the microscope.
2. Mirror—Concave on one side and plain on the other.
3. Stage—The slide is kept here.
4. Clips—To hold the slide in position.
5. Arm/Body—To hold the microscope.
6. Nose Piece—For changing the objective lenses.
7. Draw Tube—Long, hollow tube for passing light.
8. Objective Lenses—Of different magnifications inscribed on them (10X, 40/45X). They are attached to the nose piece.
9. Eye Piece—At the upper tip of draw tube for observing with eye.
10. Coarse Adjustment Knob—For adjusting the draw tube to help focus the low power objective lens.

11. Fine Adjustment Knob—For fine focusing and maximum clarity under high power objective.
12. Diaphragm—To control aperture for incoming light.
13. Condenser—focuses light below the stage.

**What have you learnt?**

Microscope is used to view objects which are too small to be seen by our naked eye. Objects to be viewed are kept on a glass slide under reflected light.

**Extension**

Compare the size of a minute organism under a magnifying lens, a dissecting microscope and a compound microscope.

**Precaution**

1. Always place the microscope facing the source of light.
2. The eye piece and objective lenses should be in line.
3. Hold the microscope by the arm with one hand and support the base with the other.
4. Before using the microscope, clean the stage, lenses or mirror.

**ACTIVITY 9.5.2(a) How to study plant cells?****What is required?**

Onion bulb, slides, covers slips, forceps, needle, brush, watch glass, glycerine, safranin/methylene blue and compound microscope

**How to proceed?**

1. Take out a peel from the inner side of the fleshy scale leaf of onion bulb.
2. Put the peel in watch glass containing water and cut it into small rectangular pieces.
3. Transfer the cut pieces into another watch glass having safranin/ methylene blue, and leave the peel for about 3 minutes.
4. Wash the peel with water to remove excess stain.
5. Put a drop of glycerine in the middle of a clean slide and transfer the stained peel onto it.
6. Place the cover slip on the material by lowering it slowly with the help of a needle.
7. Remove excess glycerine with blotting paper.
8. Keep the prepared slide on the stage of the microscope and observe under low power.
9. Draw what you have observed under microscope and label the diagram.

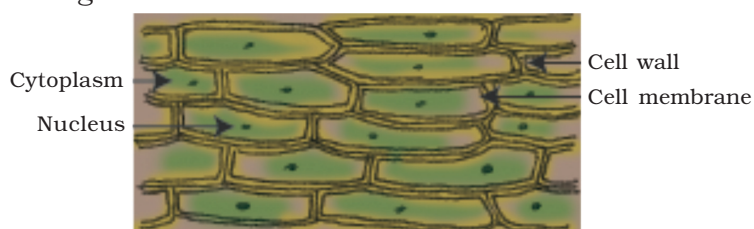

**Fig. 9.5.2(a)** Cells observed in an onion peel

**What have you learnt?**

1. The onion peel cells are rectangular in shape and compactly arranged.
2. Each cell is surrounded by a thick cell wall.
3. A dense spherical body, the nucleus, is seen in each cell.
4. Cell membrane can also be observed.



**Precaution**

While putting the cover slip care should be taken to avoid the entry of air bubbles. For this purpose keep the cover slip at 45 degree on the slide and then slowly lower it using the needle.

**Extension**

Observe leaf epidermal peel of Tradescandia/Rhoeo/Bryophyllum, onion root tip.

**ACTIVITY 9.5.2(b) How to study animal cells?****What is required?**

Wooden ice cream spoon, slides, cover slips, needle, brush, methylene blue, compound microscope and glycerine

**How to proceed?**

1. Rinse your mouth with fresh water and gently scrap the inner side of the cheek with the blunt edge of a wooden ice cream spoon.
2. Transfer the scrapped material into a drop of water on a clean slide.
3. Spread the material uniformly, and add a drop of methylene blue stain. After 3 minutes, add a drop of glycerine over the material.
4. Place a cover slip on the material, by lowering it slowly with the help of a needle.
5. Remove excess glycerine with blotting paper.
6. Keep this prepared slide on the stage of the microscope and observe under low power.
7. Draw what you have observed under the microscope and label the diagram.

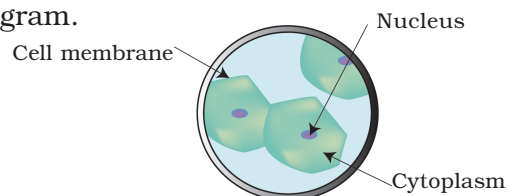

**Fig. 9.5.2(b)** Animal cells

**What have you learnt?**

1. Cheek cells are polygonal in shape.
2. Cell membrane and nucleus are visible.

**Precaution**

1. Scrap the inner lining of the cheek very gently.
2. Avoid air bubbles while placing cover slip.

**Extension**

You can observe other type of animal cells with the help of permanent slides of muscles, blood, epithelium, etc.

**ACTIVITY 9.5.3 How to study the process of osmosis?****What is required?**

Glass beaker, two raw eggs, sugar/salt solution dil. hydrochloric acid and water

**How to proceed?**

1. Keep two eggs in dil. HCl for about one hour to dissolve the shell of the eggs.

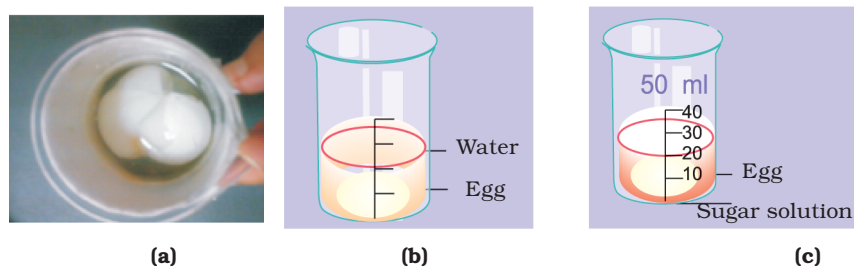

**Fig.9.5.3** (a) De-shelled eggs  
(b) Kept in water  
(c) Kept in sugar solution

2. Wash the de-shelled eggs with water thoroughly.
3. Take two beakers-one half filled with water, and the other with saturated sugar/ salt solution.
4. Put one egg in each of the beakers.
5. After about four hours, observe the two de-shelled eggs.

**What have you learnt?**

1. The de-shelled egg kept in water looks swollen with increased volume.
2. The other de-shelled egg kept in the sugar solution has shrunk in size.

**Precaution**

1. Use only dil.HCl so that the egg membrane is not damaged.
2. Ensure that the egg is completely immersed in dil. HCl.

**Extension**

You can also study osmosis in potato, carrot and raddish.

### ACTIVITY 9.5.4 How to study the processes of plasmolysis and deplasmolysis?

When cells are placed in concentrated solution (5%), the cell contents shrink resulting in plasmolysis. However, when these cells are placed in water, the cells recover due to deplasmolysis.

#### What is required?

Slides, cover slips, microscope, dropper, brush, sugar solution (5%), water, Tradescantia/ Rhoeo leaves and compound microscope

#### How to proceed?

1. Take out few epidermal peels from lower epidermis of the leaf.
2. Put one piece of peel in a drop of water on a clean slide and put cover slip over it.
3. Observe the peel under the low power of the microscope. Notice the size of the vacuoles, and pink cytoplasm.
4. Remove the cover slip and add the sugar solution.
5. Wait for five minutes, and place the cover slip back on the peel.
6. Blot out the excess solution from the sides of the cover slip.
7. Focus the cells under low power and observe.
8. Remove the cover slip and add water to the material. Observe what happens to the protoplast of the cells after 5 minutes.

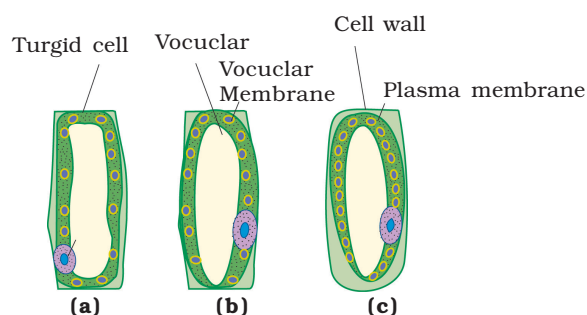

**Fig. 9.5.4** Demonstration of plasmolysis  
**(a)** A turgid cell  
**(b)** A plasmolysed cell  
**(c)** A deplasmolysed cell

**What have you learnt?**

1. In sugar solution the protoplast of the cells has shrunk away from the cell wall leaving a gap between the cell wall and cell membrane. This phenomenon is known as plasmolysis.
2. When water is added to the plasmolysed cells, they regain their earlier shape. This is known as deplasmolysis.

**Extension**

1. Take two slices of cucumber in two Petri dishes. In one, sprinkle salt and leave the other as such. Observe the difference in the surface of cucumber slices and amount of water released from both in the petridishes after 10 minutes.
2. Observe what happens to a plant when excess chemical fertilizer is added.
3. We have studied plasmolysis in the plants having red or pink natural cell sap and hence the shrinkage and expansion can be seen clearly. Staining with safranin is avoided to save the semipermeable nature of the membrane.

## 9.6 Tissues

### ACTIVITY 9.6.1 How to identify the different types of plant tissues?

#### What is required?

Blade, tender stems of any plant, glass slides, cover slips, safranin, glycerine, dissecting needle, brush, blotting paper, watch glass and compound microscope

#### How to proceed?

1. Take a small piece of tender stem and hold it vertically.
2. Cut a number of thin sections using a blade.
3. Transfer the sections into a watch glass containing water.
4. Select a section which is complete, thin and uniform, and transfer it onto a slide with a drop of water, using a brush.
5. Add one drop of safranin solution (stain) and leave it for 3 minutes.
6. Remove the excess stain by washing.
7. Add 2 drops of glycerine and put the cover slip, using needle.
8. Blot out extra glycerine and focus the slide, first under low power and then under high power.
9. Compare the slide with structure given in [Fig.9.6.1].

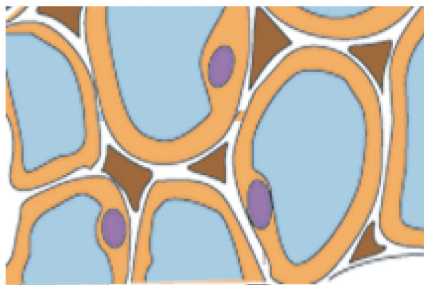

(a) Parenchyma cells



(b) Sclerenchyma cells

**Fig. 9.6.1.** Two types of simple plant tissues

**What you have learnt?**

1. The group of cells with thin cell wall and intercellular space is called parenchyma.
2. The tissue which has thick cell wall and small lumen is called sclerenchyma.
3. Vascular bundles are made up of complex tissues called xylem and phloem.

**Precaution**

1. Select tender herbaceous stem.
2. Sections should be kept in water.

### ACTIVITY 9.6.2 How to identify different types of animal tissues?

#### What is required?

Permanent slides of striated muscles and nerve fibres, compound microscope

#### How to proceed?

1. Keep the permanent slides of striated muscles and nerve fibres one by one under low power and then under the high power of microscope.

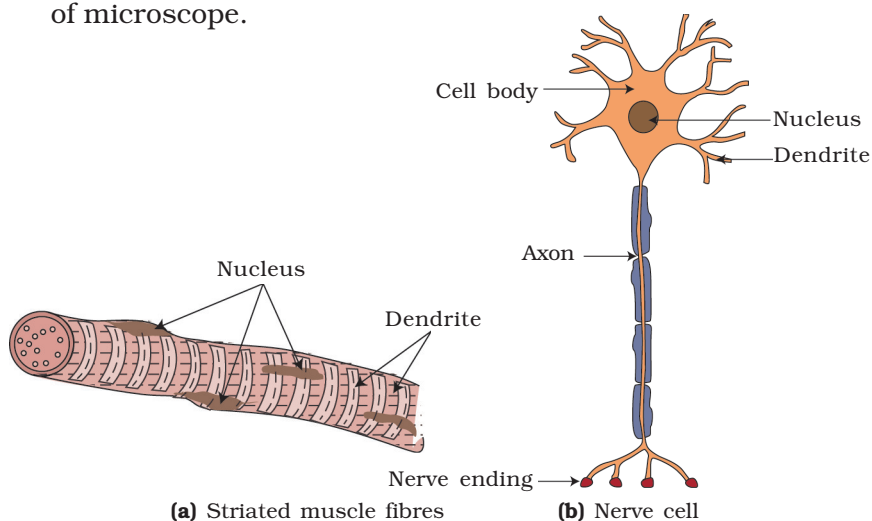

**Fig. 9.6.2** Two types of animal tissues

2. Carefully study the different characteristics of each tissue.

#### What have you learnt?

##### (A) Striated muscle fibres

1. The cells are long, cylindrical, non-tapering and unbranched.
2. They are multi-nucleated.
3. Light and dark bands are seen alternating with each other.

##### (B) Nerve cell

1. Nerve cell has a cell body, a nucleus, dendrites and axon.

#### Extension

Similarly, study various types of animal tissues like blood, bone, cartilage, etc.



## 9.7 Diversity in Living Organisms

### ACTIVITY 9.7.1 How to study diversity in plants?

Range of diversity in plants is very wide from simple forms like algae to complex Angiosperms like rose, mango, peepal etc.

#### What is required?

Slide of Spirogyra, specimens of Agaricus, Moss, Fern, Pinus (leaves and cones), any annual angiosperm (Specimen can be collected from the lab/natural surroundings) and compound microscope

#### How to proceed?

##### 1. Spirogyra

- i. Keep the slide of Spirogyra under the low power of the microscope and observe.
- ii. Draw and label the diagram. Spirogyra is an alga found in pond as slimy filaments.
- iii. It has green filamentous and unbranched body. Each filament has long cells joint end to end.
- iv. Each cell has spiral, ribbon-shaped chloroplast. Each cell has a single nucleus and a large vacuole.

##### 2. Agaricus (an edible mushroom)

- i. We see the fruiting body of Agaricus which is fleshy and umbrella-like.
- ii. Mature plant body is divided into a stalk and a cap called pileus.
- iii. A ring- like annulus is attached at the base of stalk.
- iv. The cap has gills which bear spores.

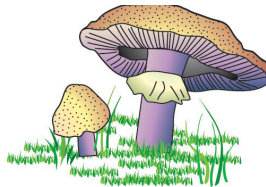

**Fig. 9.7.1(a)** Agaricus (a mushroom)

##### 3. Moss (found on damp walls and tree trunks)

- i. The plant body is about 1-3 cm long, differentiated into a central axis, leaf- like structures and root- like rhizoids.

- ii. The central axis is erect, branched or unbranched.
- iii. Small leafy structures are arranged in a circular fashion on the stem like structure.
- iv. Long rhizoids are present at the base of the stem.



**Fig. 9.7.1 (b)** Moss

#### 4. *Fern*

- i. Plant body is differentiated into stem, root and leaves.

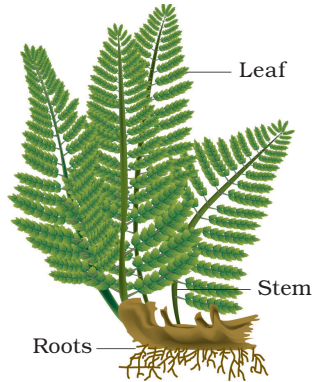

**Fig. 9.7.1(c)** Fern

- ii. The stem is short, stout and underground. It is called rhizome.
  - iii. The leaves are compound with small leaflets arranged on either side of the rachis.
- #### 5. *Pinus* (a cone bearing tree)
- i. *Pinus* is a tree with stem, leaves and roots.
  - ii. The plant has hard, woody stem.
  - iii. Male and female cones are the reproductive organs.
  - iv. Male cones are smaller and tender. Female cones are larger and woody when mature.

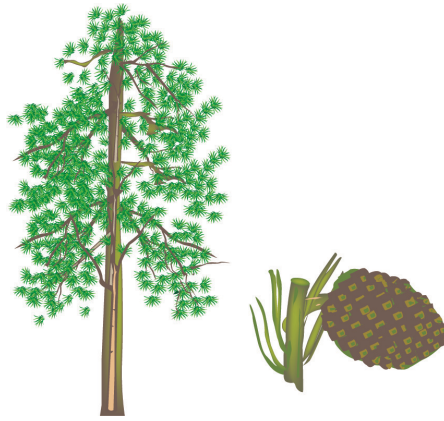

**Fig. 9.7.1(d)** Pinus with cone

6. *Angiosperm plant* (say Mustard Plant )

- i. The plant body is divided into roots, stems and leaves.

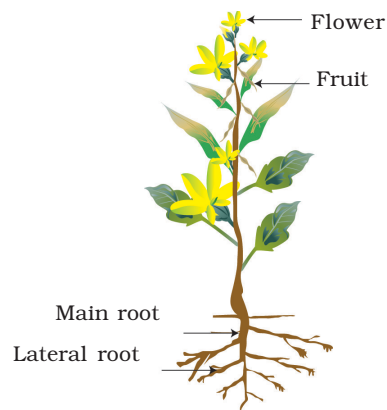

**Fig. 9.7.1.(e)** Mustard plant

- ii. Stem has nodes and internodes.  
 iii. Leaves arise from nodes.  
 iv. Plants have flowers and fruits.

**Extension**

Similarly, study other plants growing around your school and home.

**Precaution**

1. Beware of thorns on some plants.
2. Do not touch all wild mushrooms as some may be poisonous.

### ACTIVITY 9.7.2 How to differentiate a dicot from a monocot plant?

Angiosperms are of two types – dicot and monocot.

#### What is required?

Magnifying lens, newspapers, forceps, scissors, a dicot plant (Amaranthus, chaulai) and a monocot plant (grass) and seeds (pulses, wheat, rice, maize etc.)

#### How to proceed?

1. Observe the differences in leaf venation, roots and seeds.
2. Roots may be washed and spread on a newspaper to study the details.
3. Study the shape and venation of leaves.
4. Remove the seed coat and count the number of cotyledon (soak the seeds whatever required).

Draw and label the diagrams.

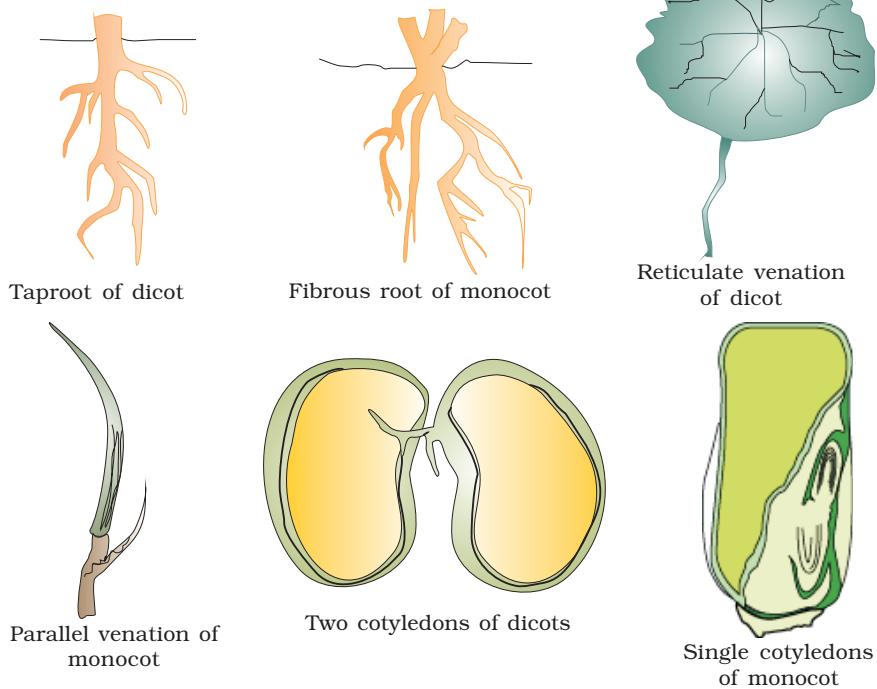

**Fig.9.7.2.** Differences between dicot and monocot plants

**What have you learnt?**

1. Dicot plants have tap roots, leaves with reticulate venation and seeds with two cotyledons.
2. Monocot plants have fibrous roots, leaves with parallel venation and seeds with one cotyledon only.

**Extension**

1. Study some more common plants growing around you.
2. Fill your observation in the table given below and classify them into monocot and dicot plants.

S.No.	Plant	Root (Tap / Fibrous)	Leaf venation (Parallel/ Reticulate)	Seed cotyledons (one/two)	Conclusions (Monocot/Dicot)
1.					
2.					
3.					
4.					
5.					
6.					
7.					
8.					
9.					
10.					

**ACTIVITY 9.7.3 How to prepare a herbarium sheet?****What is required?**

Plant specimen or a twig with leaves and flowers, thick white sheet (40 cm X 28 cm), old newspapers, adhesive, sewing needle and thread.

**How to proceed?**

1. Collect a small plant or twig with leaves and flowers.
2. Remove the moisture by keeping the plant /plant part inside the folds of the newspaper and keep a heavy book or brick on it.
3. Keep changing the newspaper daily, till the plant is properly dried.
4. Transfer the dried plant carefully onto a herbarium sheet and stitch the plant on the sheet using a needle and thread.
5. At the right bottom corner of the sheet stick a label with adhesive which has your name, name of the plant, place and date of collection.

**Precaution**

1. Atleast one leaf should be kept upturned, to expose the ventral surface.
2. Do not select aquatic and succulent plants for herbarium.
3. Care should be taken to dry the plant completely before mounting.
4. Use of cellophane/tape or adhesive to stick the plant should be avoided.

**ACTIVITY 9.7.4 How to study diversity in animals?**

There is a vast variety of animals around us – from a single celled Amoeba to the complex human being.

**What is required?**

Specimens flashcards of earthworm, cockroach, bony fish and bird

**How to proceed?**

1. Closely observe the specimens and record one specific feature of the group to which it belongs.
2. Draw the diagram of each specimen.
3. Note down one adaptive feature of each specimen.

**What have you learnt?**

a) *Earthworm* –[Phylum: *Annelida*]

- i. Body is divisible into distinct annular segments called metameres.

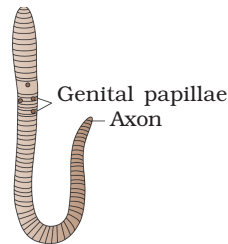
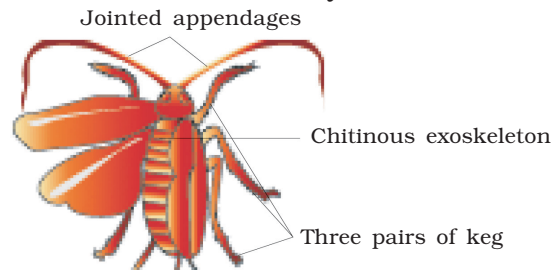

**Fig.9.7.4(a)** An earthworm

- ii. Skin moist and slimy.

b) *Cockroach* –Phylum: [*Arthropoda* ; Class : *Insecta*]

- i. Jointed appendages, segmented body, three pairs of legs.
- ii. Chitinous exoskeleton over the body.



**Fig. 9.7.4(b)** A cockroach

c) *Bony fish* – [Phylum: Chordata; Class: Pisces]

- i. Streamlined body bearing fins adapted for swimming.
- ii. Four pairs of gills present which are covered by operculum.

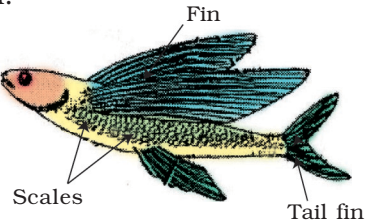

**Fig. 9.7.4(c)** A fish

d) *Bird* - [Phylum: Chordata ; Class : Aves]

- i. Body is covered with feathers.
- ii. Has a pointed beak.
- iii. Forelimbs are modified into wings.

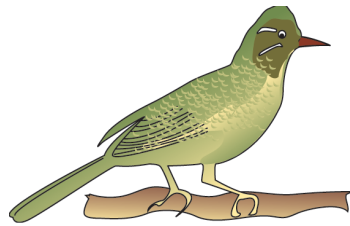

**Fig. 9.7.4(d)** A bird

**Extension**

Observe the animals around, note their characteristic features, and assign them to their respective groups.



**ACTIVITY 9.7.5 How to study the life cycle of an insect?**

There are different stages in the life cycle of certain organism.

**What is required?**

Permanent slides and charts depicting various stages of life cycle of mosquito (egg, larva, pupa, adult) and compound microscope

**How to proceed?**

1. Observe the chart and study each stage carefully.

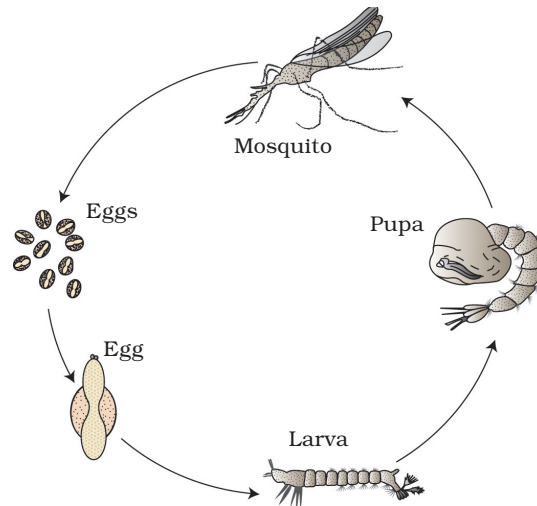

**Fig. 9.7.5** Various stages of life cycle of a mosquito

2. Note the characteristics of each stage.
3. Draw diagram of all the stages.
4. Compare what you have observed in the chart with the stages of mosquito as seen under the microscope.

**What have you learnt?**

1. The mosquito has an indirect development where distinctly different stages (from egg to adult) exist. This phenomenon is known as metamorphism.
2. Various stages show differences in their morphological features (physical features).
3. Eggs are laid in stagnant water bodies. Larvae hatch out from

the eggs and undergo moulting 5-6 times (sheds the outer cover 5-6 times).

4. Pupa does not feed and remains inactive. Adult emerges from the pupa.

**Extension**

Study the stages of life cycle of housefly and cockroach.

### ACTIVITY 9.7.6 How to study the life cycle of malarial parasite (*Plasmodium*)?

#### What is required?

Chart depicting various developmental stages of life cycle of *Plasmodium*

#### How to proceed?

1. Study different stages of life cycle of *Plasmodium* from the chart.
2. Draw a flow chart of the stages.

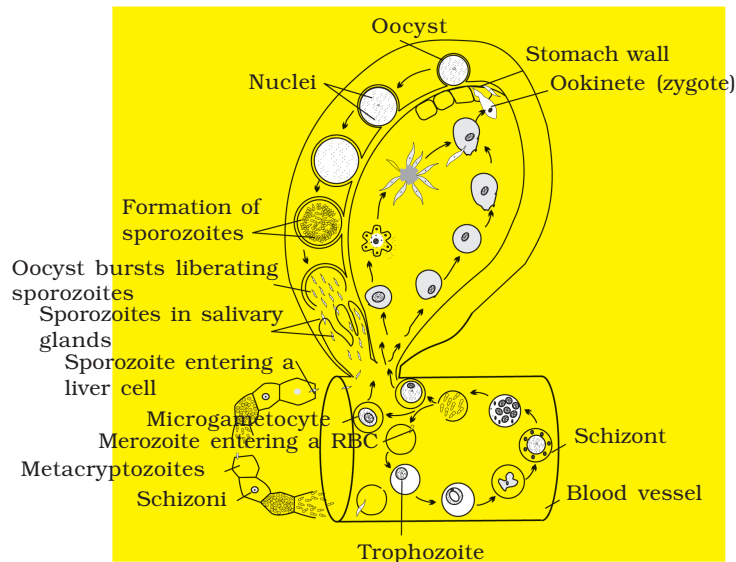

Fig. 9.7.6. Different stages of life cycle of a *Plasmodium*

#### What have you learnt?

1. *Plasmodium* completes its life cycle partly in human beings and partly in the female *Anopheles* mosquito.
2. The parasite enters the human body as sporozoites (infective stage) through mosquito bite and completes its life cycle in liver and red blood cells.
3. They release toxins from the ruptured red blood cells causing the symptoms of malaria in human beings.
4. Some of the parasite cells form male and female gametocytes.
5. These gametocytes enter a fresh mosquito while feeding on

the patient's blood. Fertilisation occurs in the midgut of mosquito and resultant stage is called an oocyst. Oocyst ruptures to release sporozoites which migrate to the salivary gland of mosquito.

6. When this mosquito bites a healthy human being, the sporozoites enter into his body.

**ACTIVITY 9.7.7 How to study diseases in locally available crops?**

Many parasitic organisms cause disease in various crops.

**What is required?**

Forceps, scissors, slides, diseased plant parts like stems, leaves, fruits, etc.

**How to proceed?**

1. Collect some diseased plants from crop fields / farms / gardens.
2. Observe the diseased plant parts closely for symptoms like discolouration, infection spots, coloured patches, stunted growth, swellings, curling and yellowing of leaves, and soft and decaying parts.
3. Draw and label the infected part.

**What have you learnt?**

1. The diseased parts show signs of infections.
2. Infected plants can be identified by specific symptoms.

**Extension**

1. List the pests that attack stored cereals at home.
2. Suggest home remedies to control them.
3. Observe red patches and note the alcoholic smell in the infected sugar cane.

## 9.8 Motion

### ACTIVITY 9.8.1 How to determine the direction of motion of a body moving in a circular path?

#### What is required?

Strong thread about 1 m and an eraser

#### How will you proceed?

1. Tie the eraser at one end of a piece of thread of length about 70-80 cm.
2. Hold the thread at the other end and move the eraser fast in such a way that it describes a circular path.
3. Release the thread from your hand. What do you observe? In which direction the eraser moves when it is released?
4. Repeat the activity by releasing the eraser at different positions of the circular path. Note down the direction in which it moves now? Does the direction in which eraser moves remain the same in each case.

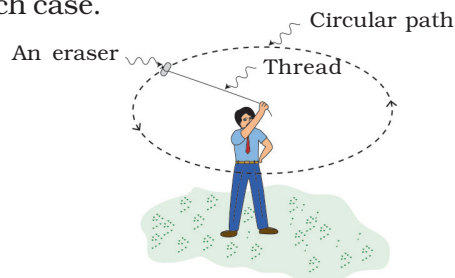

**Fig. 9.8.1** An eraser moving in a circular path

Note: This activity should be done in a safe open space.

#### What have you learnt?

1. When a body moves in a circular path its direction of motion changes at every point.
2. At any point the direction of motion is along the tangent to the circle at that point.

#### Extension

Change the length of the thread and repeat the activity. Do you find any change in the direction of motion of the eraser?

## 9.9 Force and Laws of Motion

### ACTIVITY 9.9.1(a) How are the directions of action and reaction forces related?

#### What is required?

Syringe, sleeve (thin flexible tube), aluminium wire about 5 cm long and a beaker.

#### How will you proceed?

1. Take a syringe and fit a sleeve (thin flexible tube) of about 15 cm length to its nozzle.
2. Insert the aluminium wire into the sleeve and bend it into a  $90^\circ$  arc of a circle.
3. Dip the sleeve in water kept in a beaker and pull out the piston of the syringe so that the syringe is filled with water. You inevitably pull in some air bubbles too. Push the bubbles out and once more completely fill the syringe with water.
4. Take the sleeve out of water. Hold it stable horizontally against the edge of a table, with bent wire pointing to side.
5. Push the piston inwards.
6. Observe in which direction the stream of water comes out of the sleeve?
7. Also observe simultaneously, what happens to the sleeve? It moves opposite to water stream. Is there any force acting on the sleeve? What is the direction of this force? Repeat Steps 3 to 7 several times and conclude from your observations.

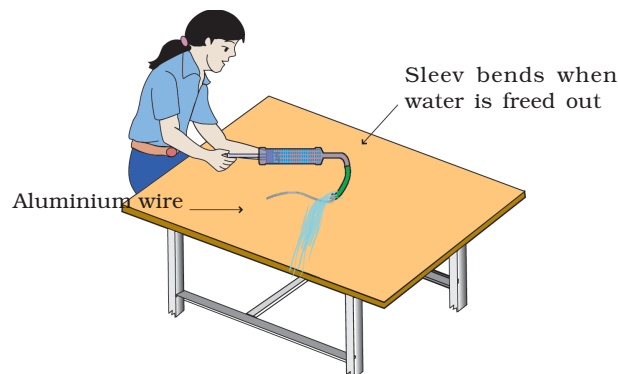

**Fig. 9.9.1(a)** Arrangement to show the action and reaction forces

**What have you learnt?**

As the stream of water comes out from the sleeve, the sleeve moves in opposite direction. This shows that moving out of water is due to force of the action. Movement of the sleeve is due to force of reaction. The action and reaction forces act in the opposite directions.

**Extension**

Repeat this activity by pressing the piston slowly and quickly. Do you find any effect of it on the motion of sleeve in backwards direction?

Alternatively, the above relationship between directions of action and reaction forces can be learnt by the following activity also.



### Activity 9.9.1(b) Are the direction of action and reaction forces related?

#### What is required?

A balloon, a straw, thread, a pair of scissors and an adhesive tape

#### How will you proceed?

1. Pass a thread of about 4 m to 5m length through a straw and tie it across the length or breadth of the room.
2. Take a big balloon. Inflate it fully and hold its neck so that air does not come out. Move the straw near one end of the thread, and keep the inflated balloon under the straw in contact with it, the neck of the balloon facing the wall as shown in [Fig. 9.9.1(b)].

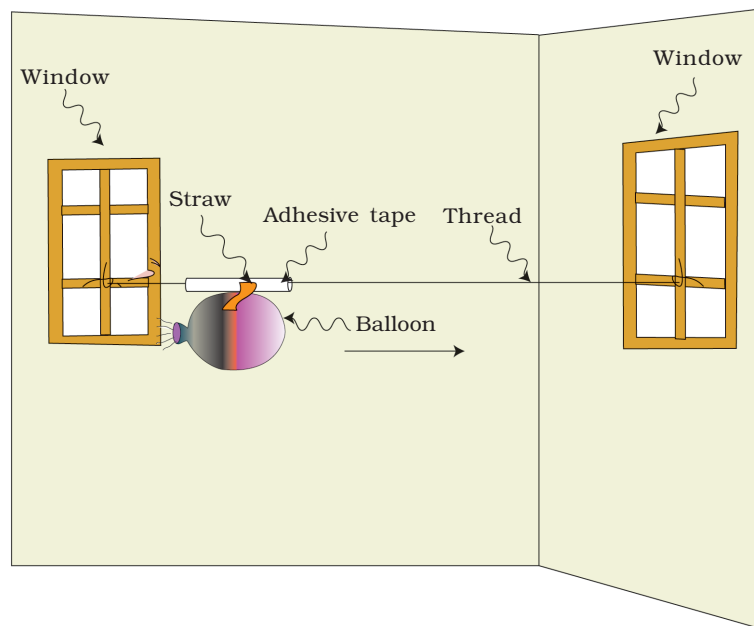

**Fig. 9.9.1(b)** Arrangement to show the direction of reaction forces

3. Let your friend stick the balloon under the straw by at least two pieces of sticking tape.
4. Now release the balloon. What happens to the balloon? In what direction does it move? In which direction does air escape from the balloon?

**What have you learnt?**

The balloon and the air escaping from the balloon move in opposite directions. Thus, action and reaction forces act in the opposite directions.

**Extension**

Hold the thread vertically with the balloon at the lower end and its mouth facing the ground. Also repeat the activity using balloons of different sizes.

### ACTIVITY 9.9.2 How to demonstrate third law of motion?

#### What is required?

Two identical spring balances

#### How will you proceed?

1. Take two identical spring balances and join their hooks.
2. Hold them horizontally in your hands as shown in [Fig 9.9.2].

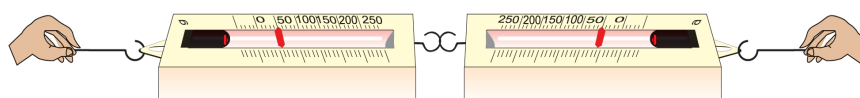

Spring Balance

**Fig. 9.9.2** Action and reaction forces are equal and opposite

3. Keeping one spring balance fixed in your left hand, pull the other spring balance with your right hand. Ensure that the rods of the spring balances do not touch their bodies.
4. Observe the readings of scales on both the spring balances. Are they equal?
5. Pull the right hand spring balance with a different force. Observe the readings on both the spring balances again. Are the two respective readings equal in each case?
6. What is the direction of action and reaction forces when you are pulling the spring balances? What do you infer?

#### What have you learnt?

The readings on both the balances are the same in each case. The action force exerted by the spring balance held in right hand is equal to the reaction force exerted on the spring balance held in the left hand. Thus, action and reaction forces are equal and opposite and act on two different bodies.

#### Extension

Repeat the activity by holding two spring balances vertically. Are the readings on both balances the same again?

**ACTIVITY 9.9.3 Does the total momentum of a system of bodies remain the same when they collide?****What is required?**

Two steel balls suspended by two threads each in V-shaped just touching each other when at rest

**How will you proceed?**

1. Let the two steel balls be at rest touching each other, as shown in [Fig. 9.9.3].
2. Now deflect one ball away from the other keeping the two threads (by which it is suspended) stretched, through an angle of at least  $30^\circ$  from vertical.

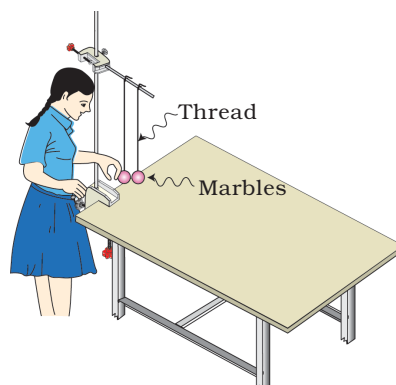

**Fig.9.9.3.** Arrangement to show that the total momentum of a system is the same before and after collision

3. Gently release this ball so that it starts its motion with zero initial velocity.
4. Observe what happens when it hits the second ball?
5. You will find that after the collision, the first ball comes to rest and the second ball moves ahead. As the second ball reaches its maximum deflection, hold it there and try to estimate whether this deflection seems to be equal to or less than or greater than the deflection of first ball when it started motion. Perhaps, you guess that the two deflections are equal. Hence, the speed of second ball after collision was equal to speed of first ball just before collision. Thus, total momentum of the balls is same before and after the collision.
6. Repeat this activity by releasing the first ball at various deflections.

**What have you learnt?**

Total momentum of a system of bodies before collision is the same as after collision.

**Extension**

If you can make this apparatus using two equal wooden balls (after used by children for playing). Then perhaps the first ball does not fully come to rest. Try to estimate how far two balls deflect after collision and whether their total momentum after the collision is the same as before the collision.

## 9.10 Gravitation

### ACTIVITY 9.10.1 Does the pressure depend upon area on which force is exerted?

#### What is required?

A square wooden board of dimensions (10 cm × 10 cm × 1 cm) with four nails fixed at corners, a plastic tray, sand and an object of about 200 g (a stone or sand in a pouch).

#### How will you proceed?

1. Fill a plastic tray with sand to a depth of about 5 cm.
2. Put the wooden board over the sand with pointed side of the nails facing downwards as shown in [Fig 9.10.1(a)]. Also put the weight on the board.
3. Observe the depth of the nails upto which they penetrate into the sand.
4. Now put the wooden board on the sand with head of the nails facing downwards [Fig 9.10.1(b)]. Again put the weight on the board.
5. Observe the depth upto which the heads of the nails penetrate into the sand.
6. In which of the above two cases the penetration is more?
7. Do you find any relation between the penetration of the nails and areas of contact of the nails with the sand in above two cases?

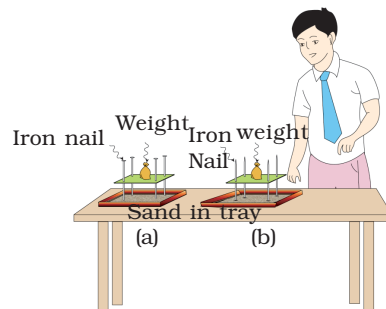

**Fig. 9.10.1** Arrangement to show pressure depends upon the area on which force is exerted

#### What have you learnt?

The same force acting on a smaller area exerts a larger pressure and a smaller pressure on a larger area.

### ACTIVITY 9.10.2 How does the pressure vary with the depth of a liquid?

#### What is required?

A funnel, a large rubber balloon, a plastic U tube, thread, rubber tube of about 30-40 cm length, bucket and water.

#### How will you proceed?

1. Fix a balloon on the mouth of a funnel with the help of a piece of thread in such a way that balloon acts as a stretched membrane.
2. Connect one end of rubber tubing with stem of the funnel and the other end with U tube.
3. Fill water in U tube .You will observe that the water level is the same in both the limbs of the U tube.
4. Now dip the mouth of the funnel in a bucket/container having water as shown in the [Fig 9.10.2].

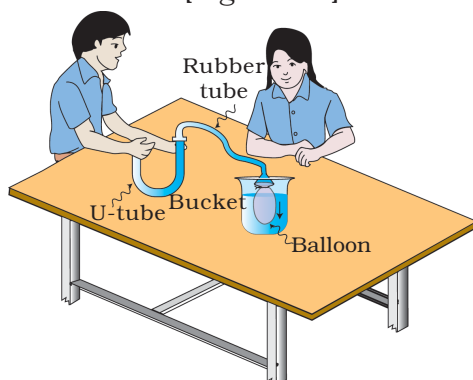

**Fig. 9.10.2** Experiment set up to show that pressure increases with depth in a liquid.

5. Observe what happens to the water level in the two limbs of the tube?
6. Now lower the funnel in to water in the bucket to different depths. What difference do you observe in the level of water in the two limbs of the U-tube? In which case the difference in the level of water in the two limbs is maximum? What do you conclude from these observations?

#### What have you learnt?

Pressure in liquids increases with depth.

**Extension**

Repeat the above activity at any particular depth of the liquid in the bucket by moving the funnel sideways. What changes do you get in your readings?



**ACTIVITY 9.10.3 Why do you feel an upward push when a solid is immersed in a liquid?****What is required?**

Plastic bottle, a bucket and water

**How will you proceed?**

1. Take an empty plastic bottle.
2. Close its mouth with an airtight stopper and push it vertically downwards into a bucket filled with water.
3. Do you feel an upward push? Why is there difficulty when you are pushing the bottle into the water?
4. Push the bottle deeper and deeper into the bucket. Why is there more difficulty when the bottle is pushed deeper into the water?
5. Now you push the bottle still deeper into water till it is fully immersed. If you push it further deep into water, do you still feel more difficulty? If not, why?
6. Now release the bottle, what do you observe? Why does the bottle bounce back to the surface of water?

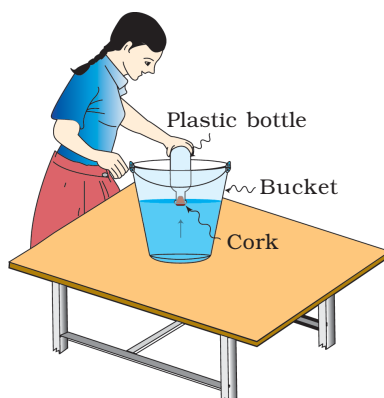

**Fig.9.10.3** Arrangement to show the existence of buoyant force

**What have you learnt?**

An upward force is exerted when a solid is immersed in a liquid. It is known as buoyant force. The buoyant force becomes constant when the body is fully immersed.

**ACTIVITY 9.10.4 How can you determine the density of a solid denser than water?****What is required?**

A metal bob with a hook, thread, measuring cylinder and spring balance

**How will you proceed?**

1. Take a metal bob with a hook. Suspend it from the hook of a spring balance using a thread. Note down its mass (though the spring balance gives weight to the spring balance given in the kit is calibrated to measure the mass.)
2. Take a measuring cylinder and fill about half of it with water. Note the reading of water level in the measuring cylinder. Now suspend the bob in the measuring cylinder so that it is completely immersed in water.
3. Note down the level of water in the measuring cylinder.
4. The difference in the two readings of the measuring cylinder is the volume of the metal bob.
5. Find out the ratio of mass of the bob in air to the volume of the metal bob. This gives you the density of material of the bob.

**What have you learnt?**

The ratio of mass of a body to its volume is equal to the density of the material of which the body is made.

**Extension**

Take a body of larger size and using an overflow can and a measuring cylinder, determine the volume of water displaced when the body is immersed fully in water. Hence, find out the density of the material of the body.

**ACTIVITY 9.10.5 Does a body experience a buoyant force when it is immersed fully or partially in a liquid? What is the relation between this force and the weight of the liquid displaced by the body?**

**What is required?**

An overflow can, measuring cylinder, spring balance, thread, a piece of stone, a wooden block and an iron stand

**How will you proceed?**

1. Place an overflow can on a wooden block and fill it completely with water.
2. Take the measuring cylinder and place it under the spout of the overflow can.
3. Suspend a piece of stone from the hook of the spring balance with the help of a thread.
4. Note the reading of the spring balance.
5. Lower the stone into water in the overflow can such that about half of it gets immersed in water.
6. Collect water displaced by the stone in the measuring cylinder and note its volume.
7. Also note the reading of the spring balance while the stone is partly immersed in water. It is the weight of the stone when it is partially immersed in the water. Is there any relation between the weight of the stone in air, weight of water collected in the measuring cylinder and weight of the stone when partially immersed in water (Take weight of 1 mL of water = 1g).
8. Further lower the stone into water till it gets completely immersed in it. Again note volume of water collected in the measuring cylinder and the reading of the spring balance.
9. Do you find any relation between the loss in weight of the stone immersed in water and the weight of displaced water?

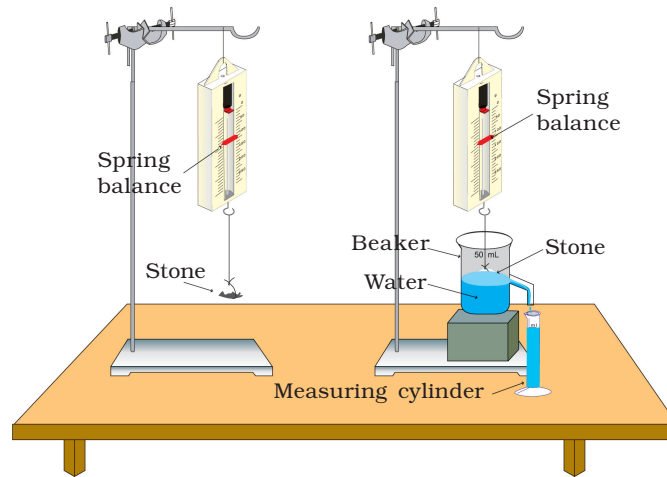

**Fig. 9.10.5** Arrangement to show the buoyant force

### **What have you learnt?**

When a body is immersed fully or partially in a liquid (or any fluid), it experiences a buoyant force which is equal to the weight of the liquid displaced by it. This is known as Archimedes principle.

### **Extension**

Immerse the stone in tap water and then in concentrated salty water and find the loss in weight in both cases. In which case the buoyant force is more?

## 9.11 Work and Energy

**ACTIVITY 9.11.1 How to determine if potential energy possessed by an object depend upon its position or configuration?**

**What is required?**

One empty wooden spool, a thick rubber band of about 8 cm length, thread and a straight straw.

**How will you proceed?**

1. Take an empty wooden spool.

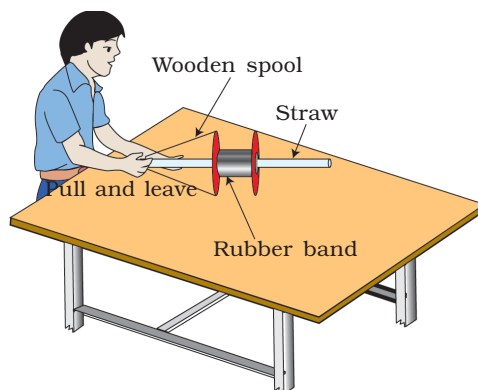

**Fig. 9.11.1** Arrangement to show the potential energy possessed by the stretched rubber band

2. Cut the rubber band at some point and tie it with the wooden spool with the help of thread, as shown in [Fig. 9.11.1].
3. Hold the wooden spool in your left hand. Pass the straw through the axis of the spool. By right hand hold one end of the straw attached to centre of the rubber band. Then stretch and release the rubber band. What do you observe? Why does the straw move in the forward direction?
4. Try the activity a few times by pulling the rubber band to different extents. How is the distance to which the straw moves related to the extent of pulling the rubber band?

Note: It will be a safer and better demonstration if you throw the straw upwards. Height to which it rises will also give an idea of amount of energy received by it from the rubber band.

**What have you learnt?**

Potential energy possessed by an object depends upon its position or configuration.

**Extension**

Repeat the above activity by taking a bow and arrow.

**ACTIVITY 9.11.2 Are potential and kinetic energies interconvertible?****What is required?**

Large size Yo-Yo

**How will you proceed?**

1. Wrap the thread on the axle of the Yo-Yo by rotating the wheel.
2. Hold the free end of thread in your hand and release the wheel. What do you observe? You will find the wheel goes down and comes up repeatedly. Why does it happen?
3. At which position the potential energy stored in the wheel is maximum? At which position to the kinetic energy of the wheel is maximum?

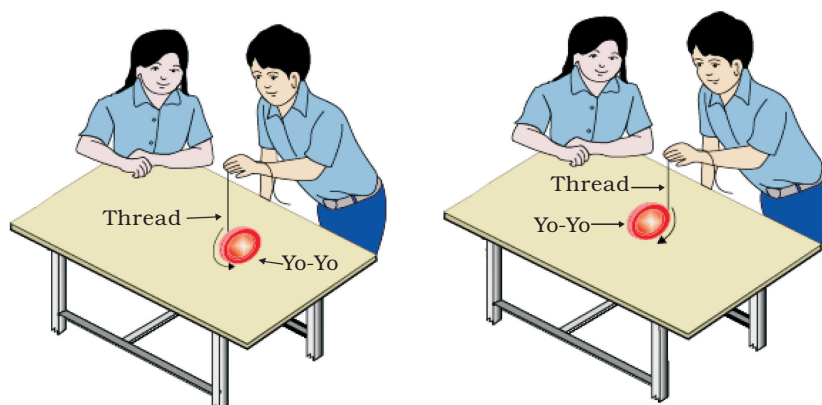

**Fig. 9.11.2** Yo-Yo

4. What happens when it is in between these two extreme positions? What do you infer from these observations?

**What have you learnt?**

Potential and kinetic energies are interchangeable.

## 9.12 Sound

### ACTIVITY 9.12.1 Are vibrations essential for producing sound?

#### What is required?

Tuning fork, plastic ball (1-2 cm diameter), thread, stand, large needle (about 8-10 cm) and rubber pad

#### How will you proceed?

1. Make a pair of diametrically opposite holes in the plastic ball.
2. Pass a thread through these holes using the needle and make a knot at one end so that the ball can be hanged vertically. Suspend the ball from the stand.
3. Strike one of the prongs of the tuning fork with a rubber pad. Do you hear any sound?
4. Touch the ball gently with a prong of the vibrating tuning fork. What do you observe?

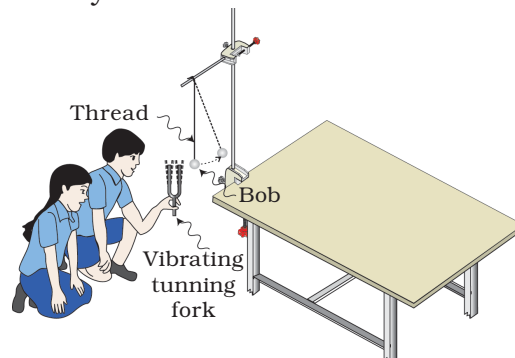

Fig. 9.12.1 Vibrations produced by a tuning fork

5. Now touch one of the prongs of the vibrating tuning fork with your finger so that it stops vibrating. Do you hear any sound now?
6. Touch the ball gently with the prong of this tuning fork again.
7. What do you observe now? Why does the ball move away in the first case and why not in the second case?
8. What do you infer from these observations?

#### What have you learnt?

Vibrations are essential for producing sound.



**ACTIVITY 9.12.2 How can you produce longitudinal waves in a slinky?****What is required?**

Slinky of about 5 cm to 8 cm diameter

**How will you proceed?**

1. Hold one end of the slinky and ask your friend to hold the other end.
2. Stretch the slinky and give a sharp push towards your friend. While doing it ask your friend not to disturb the other end. What do you observe? In which direction the pulse created by you in the slinky moves?
3. Tie a small thread somewhere in the middle of the slinky. Observe the movement of the thread while you create a pulse in the slinky by giving it a sharp push. In which direction the pulse moves in the slinky? What do you infer from this observation?
4. Now push and pull the slinky alternately at regular interval of time. What do you observe? Do you observe longitudinal waves in the slinky?
5. Notice that at some points coils in the slinky become closer and this configuration of coils coming closer, moves along the slinky. At some other points coils become further apart and this configuration too moves along the slinky. What names are given to these regions?

**What have you learnt?**

The longitudinal waves can be produced in a slinky by pushing and pulling it alternately. Thus, compression and rarefaction, alternately one after the other, travel along the slinky.

### ACTIVITY 9.12.3 How can you determine the speed of a pulse propagated through a stretched slinky?

#### What is required?

Metallic slinky of about 5 cm to 8 cm diameter, 10 m to 15 m long tightly knitted cotton string about 7 mm to 8 mm diameter, stop-clock, and measuring tape.

#### How will you proceed?

1. Take the slinky and fix its one end to a window grill/hook/handle of the door or say your friend to hold that end.
2. Hold the other end of the slinky and stretch it to about 4 m to 5 m. Give a small jerk forwards or backwards to create a pulse. Observe the pulse carefully. Is it transverse or longitudinal and why? Also observe how it gets reflected from the fixed end of the slinky.

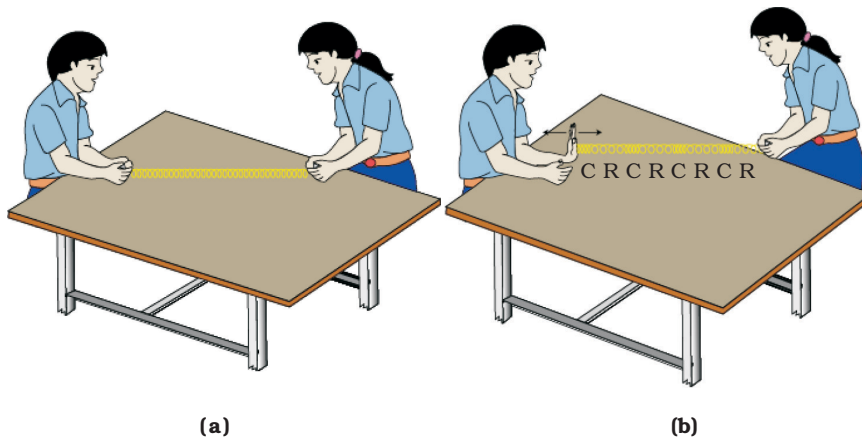

**Fig. 9.12.3** How to determine the speed of a pulse propagated through a stretched slinky

3. Adjust the tension in the slinky and amplitude of the pulse which you are producing by giving a jerk in such a way that you are able to feel 7-8 reflected pulses.
4. Ask your classmate to start the stop-clock the moment you give the jerk and speak 'START'. He notes down the time taken by the pulse in making 7-8 to and fro movement.
5. Note down the length of the slinky and find out the speed of the pulse propagated through the slinky.

Note: You have to help your friend by announcing 'STOP', after the pulse has made desired number of to and fro movement. Very soon, the pulse may become too small to be seen by your friend, though you continue feeling it every time it reaches your hand.

6. Repeat above activity by jerking the slinky up and down or sideways and determine speed of the pulse.

**What have you learnt?**

Speed of the pulse can be determined for a longitudinal pulse propagating through a slinky.

**Extension**

Repeat the above activity using a 10 m to 15 m long thick cotton string.

### ACTIVITY 9.12.4 How can you study the reflection of sound?

#### What is required?

Two chart papers/newspapers of size about 50 cm × 70 cm enrolled into cylinder of about 70 cm length and about 5 cm diameter, stop-clock and two wooden boards with arrangement to place them in upright position

#### How will you proceed?

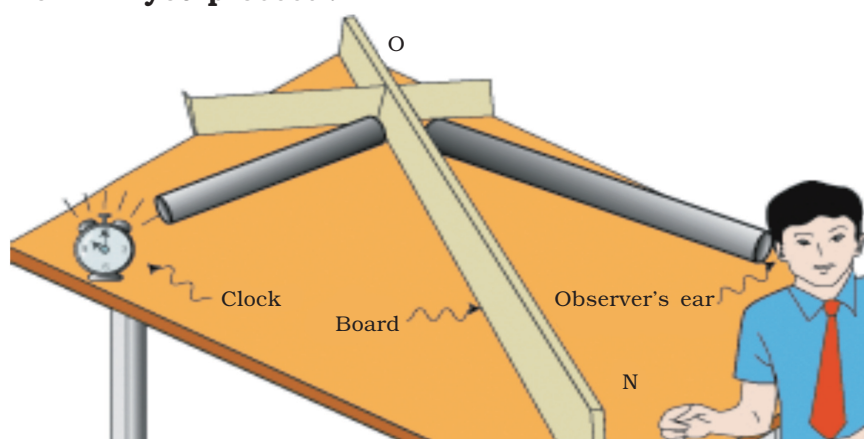

**Fig. 9.12.4** Arrangement to show the reflection of sound

1. Place one wooden board vertically on the table.
2. Put the other board along the normal O N, to the first board as shown in the [Fig.9.12.4].
3. Lay the two tubes inclined to the first board as shown in the Figure.
4. Place a stop-clock at the end of left hand tube. Place your ear close to the mouth of the right hand tube. Do you hear the ticking sound of the clock? If not, adjust the inclination of the right hand tube till you hear the ticking sound of stop-clock.
5. Now make further adjustments of the right hand tube till you hear the maximum sound. Observe the inclination of the two tubes relative to O N. Are they nearly equal? What do you infer from your observations? Repeat the above activity with different angles of inclinations.

Note: The observer keeps one ear quite into the far end of second pipe and closes the other ear by finger, so that direct sound reaching from clock to second ear of observer is NOT heard.

**What have you learnt?**

When sound is reflected from an obstacle, angle of incidence is equal to angle of reflection.

## Class X

### 10.1 Chemical Reactions and Equations

#### ACTIVITY 10.1.1 How do we know that a chemical reaction has taken place?

##### What is required?

Lead nitrate solution, potassium iodide solution, zinc granules, dilute HCl, quick lime, water, NaOH, phenolphthalein, lime stone, test tubes, a pair of tongs, common salt, iron fillings, magnet, test tube stand, dropper and micro spatula

##### How to proceed?

1. Take four test tubes and label them as A, B, C and D.
2. In test tube A, transfer a few drops of potassium iodide solution and few drops of lead nitrate solution with the help of dropper. What do you observe? Has any precipitate formed?
3. In test tube B, put a granule of zinc and transfer a few drops of dilute HCl. What do you observe?
4. In test tube C, take a spatula full of quick lime and then add 1 mL of water to it. Touch the test tube with your fingers. Is there any change in its temperature?
5. In test tube D, take a few drops of NaOH solution. Observe its colour. Transfer 1-2 drops of phenolphthalein and note the change in colour. What colour do you observe?

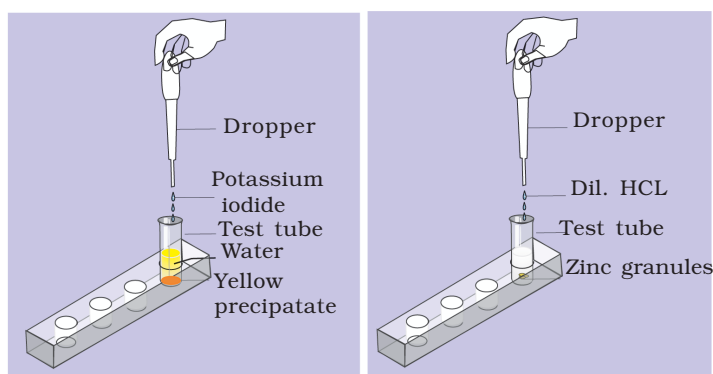

- (a) Transferring solution of potassium iodide to the test tube containing lead nitrate solution.      (b) Transferring dil. HCl to zinc granules

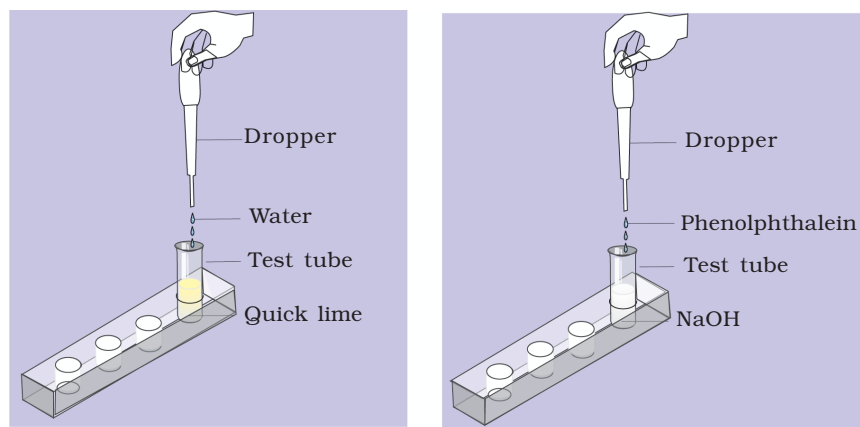

(c) Transferring water to quick lime      (d) Transferring drops of phenolphthalein to NaOH

**Fig.10.1.1** Arrangement to show various chemical reactions

- Mix common salt and iron fillings in a China dish. Is there any change in colour or temperature? Has any precipitate formed or gas evolved? Move a magnet through this mixture. What do you observe? Can we get back the components in this case easily? Has any chemical reaction taken place?

### What have you learnt?

Chemical reactions bring changes in the chemical properties of matter and we get new substances.

- In test tube A, yellow precipitate has formed.
- In test tube B, Hydrogen gas has evolved.
- In test tube C, temperature is increased and calcium hydroxide is formed.
- In test tube D, there is a change in colour to the formation of new chemical substance.
- In the China dish the magnet attracts the iron fillings and no new chemical substance is formed. Hence mixing of common salt with iron fillings is a physical change. Therefore, chemical reaction has taken place in test tube A, B, C and D as new chemical substances are formed.

**ACTIVITY 10.1.2 What are the different types of chemical reactions?****What is required?**

Copper sulphate solution, iron nails, lead nitrate crystals, quick lime, water, barium chloride solution, sodium sulphate solution, manganese dioxide, concentrated hydrochloric acid, test tubes, test tube stand, test tube holder and kerosene burner

**How will you proceed?**

1. Take five test tubes and label them as A, B, C, D and E.
2. In test tube A, add a spatula full of quick lime and then add 1 mL of water. Touch the bottom of the test tube with your fingers. What do you observe? Has any reaction taken place? Write the equation for chemical reaction. What type of reaction is it?
3. In test tube B, take a few crystals of lead nitrate and heat them. Observe the colour of gas evolved and write the chemical equation. Name the type of chemical reaction that has taken place.
4. In test tube C, take a few drops of dilute copper sulphate solution and dip an iron nail into it. After a few minutes, take out the iron nail from the test tube and observe the colour of the deposit on nail. What is the chemical compound deposited on the nail? Write the chemical equation and infer the type of reaction.

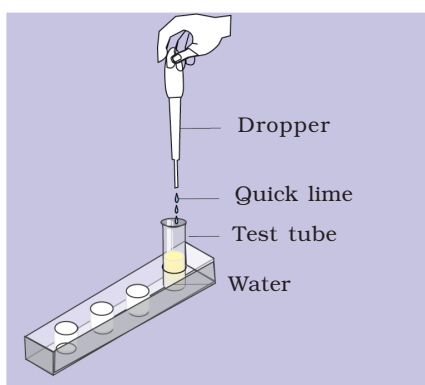
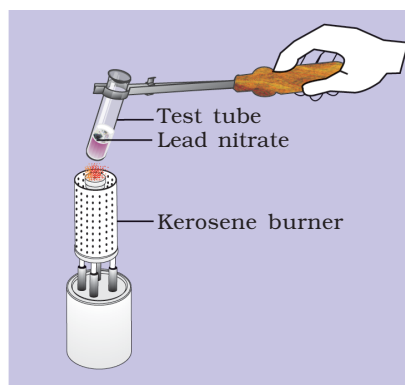
**(a)** Adding water to quick lime**(b)** Heating of lead nitrate



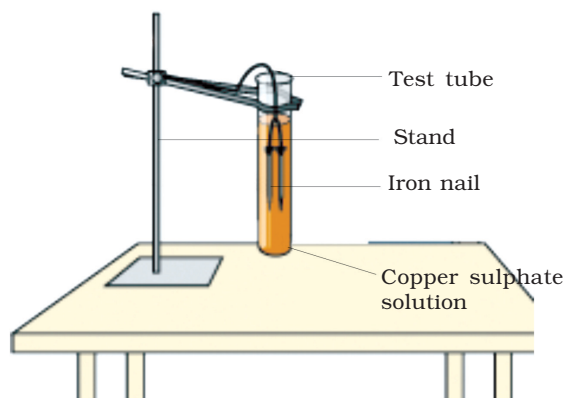

(c) Dipping the iron nail in copper sulphate

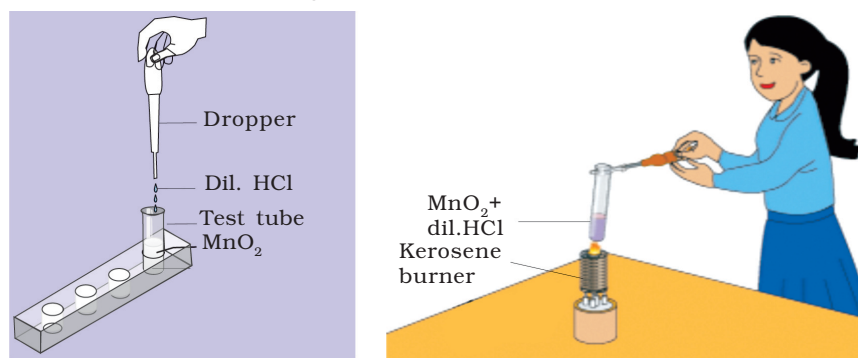
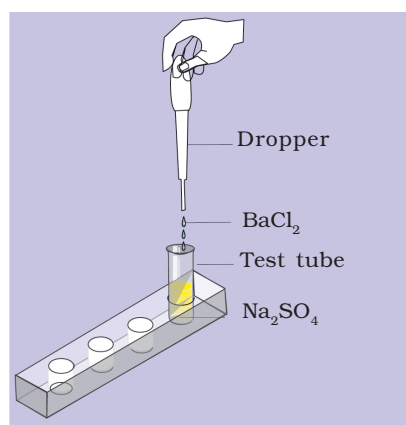
(d) Heating of  $\text{MnO}_2$  and HCL(e) Adding a few drop of  $\text{BaCl}_2$  solution and sodium sulphate**Fig. 10.1.2** Arrangement to perform different types of chemical reactions

5. In test tube D, transfer a small amount of manganese dioxide with the help of spatula and then add a few drops of dilute hydrochloric acid and heat. Observe the colour of gas evolved. Which gas is it? How do we get this gas? Write the chemical equation for the reaction. Where is the removal of oxygen and addition of hydrogen taking place? What type of reaction is it?
6. In test tube E, take a few drops of sodium sulphate solution and add few drops of barium chloride solution to it. Observe the colour of the precipitate. How is it formed? Write the chemical equation for the reaction taking place.

**What have you learnt?**

1. In test tube A, the type of reaction is combination reaction.
2. In test tube B, the type of reaction is thermal decomposition reaction.
3. In test tube C, displacement reaction takes place.
4. In test tube D, oxidation and reduction take place simultaneously; therefore, this reaction is known as a redox reaction.
5. In test tube E, a double displacement reaction takes place.

**ACTIVITY 10.1.3 What happens when an electric current is passed through water?**

Passage of electric current through many substances in their liquid state or molten state causes their decomposition. This process is called electrolysis. On electrolysis, water decomposes into its constituent elements, viz -hydrogen and oxygen.

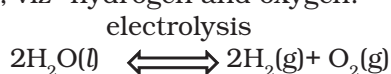
**What is required?**

Bell jar, rubber cork with two stainless steel electrodes, water, 9 V battery, plug key, connecting wires, glass rod, universal indicator solution, sodium sulphate and Pasteur pipette

(Note: If a 9 V battery is not available, a 6 V battery or four dry cells of 1.5 V fitted in a cell casing may be used)

**How will you proceed?**

1. Take about 40 mL water in a 50 mL beaker.
2. Add a few spatula full of sodium sulphate to water and stir well to prepare its concentrated solution.
3. Add universal indicator solution drop-wise till colour of the solution becomes dark green.

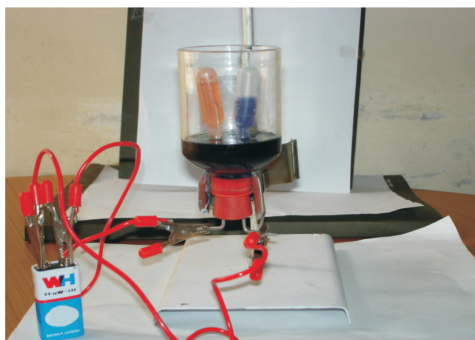

**Fig.10.1.3.** Water decomposing into its components

4. Take two Pasteur pipettes of 3 mL capacity and cut some portion of their lower ends. Fill the remaining 3 cm of its stem length completely with sodium sulphate solution.

5. Fix the rubber cork with two stainless steel electrodes in the bell jar and clamp it in the inverted position as shown in [Fig.10.1.3].
6. Fill the bell jar with the remaining coloured solution (green coloured).
7. Lower the two Pasteur pipettes filled with coloured solution over two steel electrodes carefully.
8. Connect a 9 V battery to the two electrodes with connecting wires.
9. Insert a plug key in the circuit and keep the key open.
10. Now, close the key and observe the two electrodes carefully. What do you notice?
11. Do you observe bubbles forming on the two electrodes?
12. Do you notice any colour change in the two Pasteur pipettes?
13. Find out the reason of the colour change.

**What have you learnt?**

When an electric current passes through it, water splits into two gases, hydrogen and oxygen.

**Extension**

Repeat the activity with distilled water without adding any salt and note down your observations.

**ACTIVITY 10.1.4 How will you study a redox reaction?****What is required?**

Copper powder or copper turnings, zinc granules, concentrated HCl, W-tube, China dish, wire gauge, kerosene burner and tripod stand

**How will you proceed?**

1. Take a few mg of copper powder or turnings in a China dish and place it on the tripod. Heat it over a kerosene burner for sometime.
2. Do you find any change in colour of copper powder?
3. Take a W-tube and put the compound formed in above step 1, in one of the sides of the W-tube so that it may block lower end and put a zinc granule in the other side.
4. Add few drops of Conc. HCl from the side of W-tube containing zinc granule. Close this open end of the W-tube with the help of dropper.
5. Do you observe any gas being evolved?
6. Gas would pass through the other side of W-tube containing black compound which was formed in the China dish.
7. Heat this side of the W-tube.
8. Do you observe any change in the colour of the black compound?
9. Write the chemical equations for in the chemical reactions taking place.

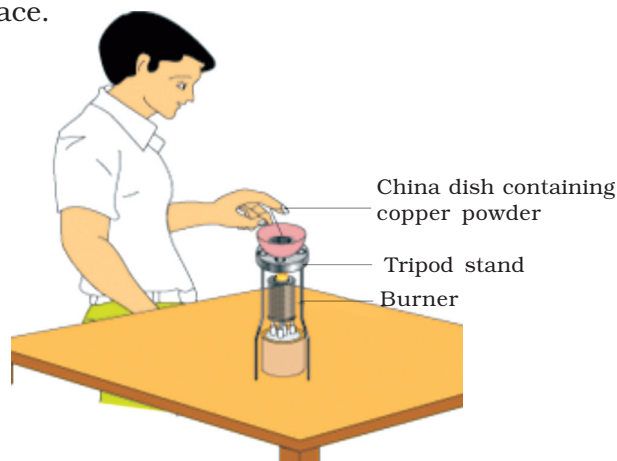

**Fig.10.1.4 (a)** Oxidation of copper to copper oxide

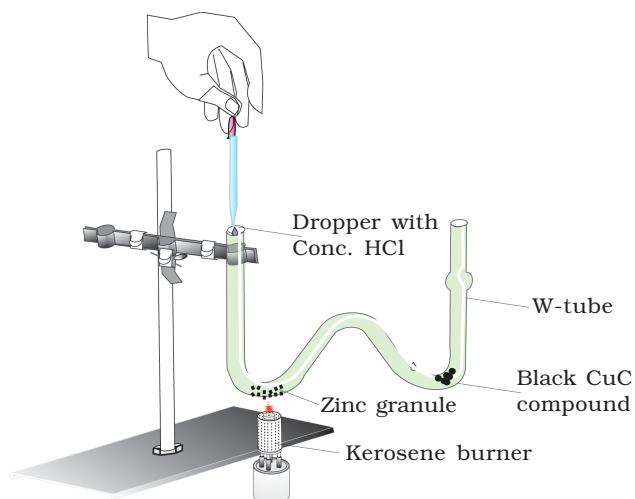

**Fig.10.1.4 (b)** Reduction of copper oxide back to copper

**What have you learnt?**

1. When copper powder is heated in air, it undergoes oxidation to form copper oxide.
2. When hydrogen gas is passed over copper oxide, it undergoes reduction and forms Cu and  $H_2O$ .
3. This reaction is an example of oxidation–reduction or redox reaction.

## 10.2 Acids, Bases and Salts

### ACTIVITY 10.2.1 How will you identify the acidic and basic nature of substances using different indicators?

#### What is required?

Blue litmus paper, red litmus paper, phenolphthalein, methyl orange, Dil.HCl, Dil.H<sub>2</sub>SO<sub>4</sub>, CH<sub>3</sub>COOH, NaOH, Ca(OH)<sub>2</sub>, NH<sub>4</sub>OH, lemon juice, coffee powder, test tubes, test tube stand.

#### How will you proceed?

##### Part A

1. Take four test tubes and label them as A, B, C and D and place them in test tube stand.
2. Put small strips of blue litmus paper, red litmus paper, a few drops of phenolphthalein and a few drop of methyl orange respectively in test tubes A, B, C and D.
3. Add a few drops of dil. HCl to each of these test tubes.
4. In which of the test tubes does the colour of the indicator change? Record your observations in the table and explain.

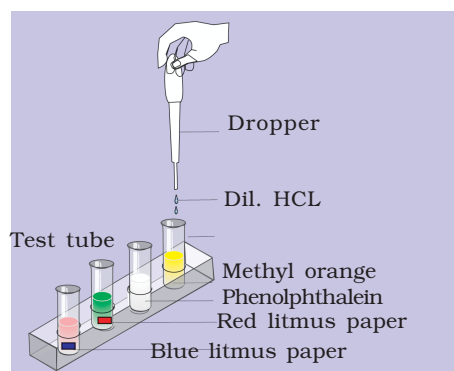

**Fig. 10.2.1** Showing the acidic and basic nature of substances using different indicators

##### Part B

Repeat the above Steps (1-3) using NaOH solution instead of dil.HCl in Step 3.

5. In which test tube does colour of the indicator change? Explain with reason. Record your observations in the table given below.

*Part C*

6. Repeat the above Steps (1-3) with each of the following solutions: dil.  $\text{H}_2\text{SO}_4$ ,  $\text{CH}_3\text{COOH}$ ,  $\text{Ca}(\text{OH})_2$ ,  $\text{NH}_4\text{OH}$ , lemon juice, coffee solution and observe the colour changes with all the four indicators.

7. Record your observations in the following table.

Sample	Change in colour of red litmus paper	Change in colour of red litmus paper	Colour with phenolphthalein	Colour with methyl orange
1. Dil.HCl				
2. NaOH solution				
3. $\text{H}_2\text{SO}_4$				
4. $\text{CH}_3\text{COOH}$				
5. $\text{Ca}(\text{OH})_2$ solution				
6. $\text{NH}_4\text{OH}$				
7. Lemon juice				
8. Coffee solution				
9.				
10.				

**What have you learnt?**

1. HCl,  $\text{H}_2\text{SO}_4$ ,  $\text{CH}_3\text{COOH}$ , lemon juice is acidic in nature and they turn the colour of blue litmus paper to red.
2. NaOH,  $\text{NH}_4\text{OH}$ ,  $\text{Ca}(\text{OH})_2$  and coffee solution are basic in nature and they turn the colour of red litmus paper to blue.
3. Acids colour is not changed with phenolphthalein.  
Bases have pink colour with phenolphthalein.
4. Acids give pink colour with methyl orange.  
Bases give yellow colour with methyl orange.

**Extension**

1. Prepare some indicators using materials available in the kitchen.



### ACTIVITY 10.2.2 What are the chemical properties of acids and bases?

#### What is required?

Zinc granules, dil. sulphuric acid, sodium hydroxide, sodium bicarbonate, hydrochloric acid, sodium carbonate, lime water, copper oxide, concentrated sulphuric acid, phenolphthalein, water, test tubes, test tube holder, W-tube, dropper and kerosene burner

#### How will you proceed?

1. Take six test tubes, label them  $A_1$ ,  $A_2$ ,  $A_3$  and  $B_1$ ,  $B_2$ ,  $B_3$ .

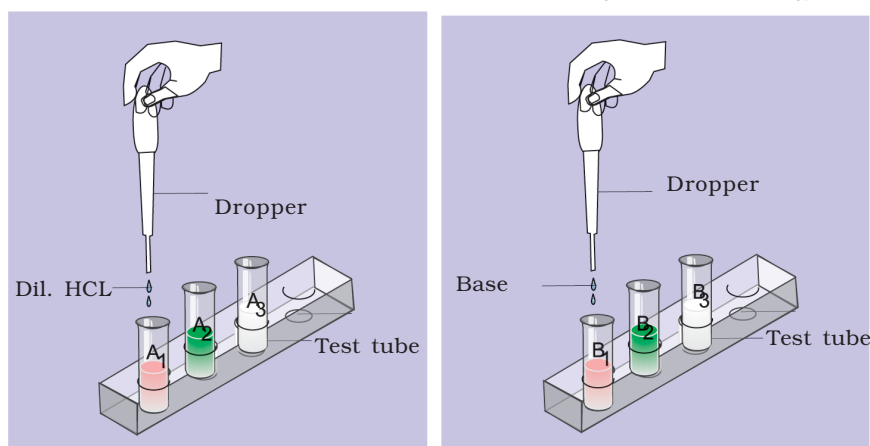

**Fig.10.2.2 (a)** Showing the chemical properties of acids and bases

2. Take a few drops of any acid ( $\text{HCl}/\text{H}_2\text{SO}_4$ ) in test tubes  $A_1$ ,  $A_2$ ,  $A_3$  and a few drops a base in test tubes  $B_1$ ,  $B_2$  and  $B_3$ .
3. Add a granule of zinc in the test tubes  $A_1$  and  $B_1$ . What do you observe? Heat the solution, if no reaction is observed at room temperature. Bring burning splinter near the mouth of the test tubes. What do you observe? In both cases,  $\text{H}_2$  gas evolves. Write the chemical equation for the reaction taking place.
4. In a W-tube, transfer some amount of sodium carbonate in one limb, and a few drops of freshly prepared lime water in the other. Transfer a few drops of acid from test tube  $A_2$  to the limb containing sodium carbonate and close this end of W-tube with the help of dropper. Has any gas evolved? How

does this gas react with lime water? What is the change in colour of lime water? Why? Repeat this with few drops of solution from tube B<sub>2</sub>. What do you observe? An acid reacts with Na<sub>2</sub>CO<sub>3</sub> to evolve CO<sub>2</sub> gas, but a base does not.

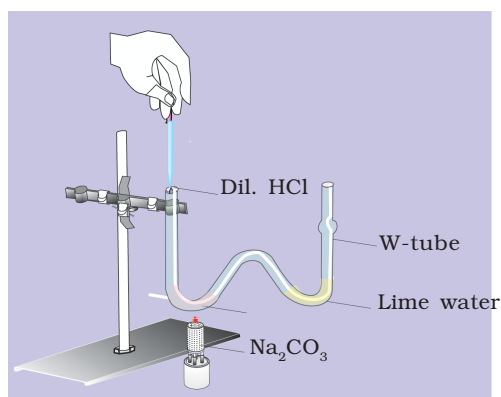

**Fig.10.2.2 (b)** Absorption of CO<sub>2</sub> gas in a W-tube

- Take a drop of each red litmus and blue litmus solution one by one on a tile. You may take pieces of blue and red litmus paper. Transfer one drop of solution from test tubes A<sub>3</sub> and B<sub>3</sub> respectively to the litmus solution/ paper one by one. What do you observe? Acids change the colour of litmus paper from blue to red. Whereas bases change the colour of the litmus from red to blue.

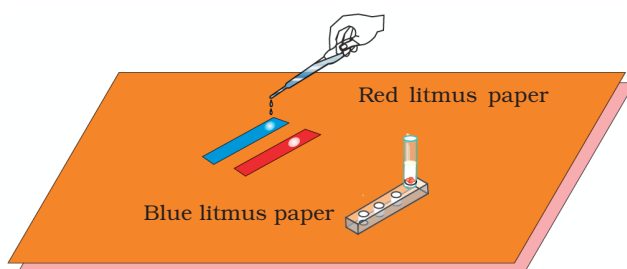

**Fig. 10.2.2 (c)** Showing of red acids and bases on red and blue litmus solution or red and blue litmus paper.

- Take a small piece of magnesium ribbon and burn it in the flame of kerosene burner. Place the compound formed on a watch glass. What is the chemical nature and composition of this compound and name it? Add water to it now. Add phenolphthalein and observe the colour change. What is the nature of the metal oxide?

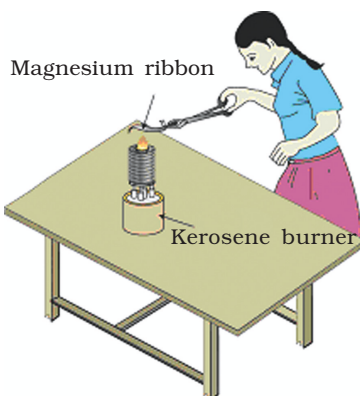

**Fig. 10.2.2 (d)** Burning of magnesium ribbon

7. Take water in two test tubes. In one, transfer a few drops of an acid slowly and in the other test tube, add small piece from one NaOH pellet. Touch both the test tubes. Is there any change in temperature? What type of reaction does acids and bases give with water?

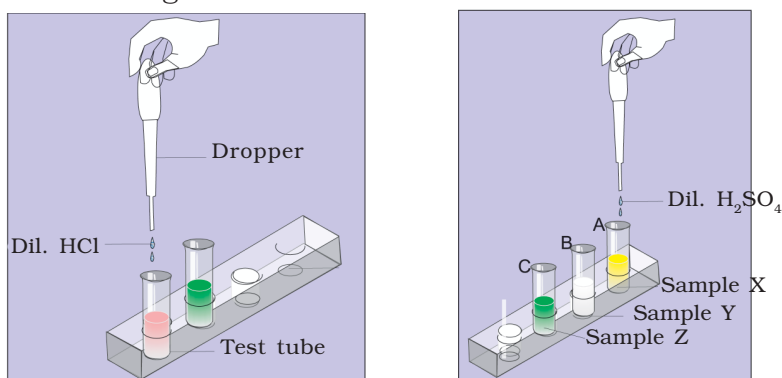

**Fig. 10.2.2 (e)** Showing reaction of acid and base with water.

8. Take the bell jar fitted with two-bore cork having electrodes of stainless steel fixed. Transfer about 20 mL of acid to it. Connect the two electrodes with 9 V battery, having a bulb in the circuit. Does the bulb glow?
9. Repeat Step 8 by replacing acid with a base. Does the bulb glow again? What do you infer when bulb glows in circuit?

#### What have you learnt?

1. Acids and bases evolve hydrogen gas with metals.
2. Metal oxides are basic in nature.

3. Phenolphthalein gives pink colour with base and decolourizes on addition of required amount of an acid.
4. Acids and bases both are good conductor of electricity.
5. Acids change the colour of blue litmus paper to red and bases changes the colour of red litmus paper to blue colour.

**ACTIVITY 10.2.3 How will you estimate the pH of given substances using pH paper/universal indicator solution?****What is required?**

Test tubes, test tube stand, dropper, universal indicator solution or pH paper, dilute solutions of hydrochloric acid, ethanoic acid, lemon juice, sodium bicarbonate solution, tap water and distilled water

**How will you proceed?**

1. Take about 3-4 drops of given samples of solutions in different test tubes and label them as A,B,C,.....
2. Do you observe any colour in any of the solution?
3. Add one drop of universal indicator solution or a piece of pH paper in each of the test tubes.
4. Do you observe any change in colour of the solution/pH paper in each test tube?

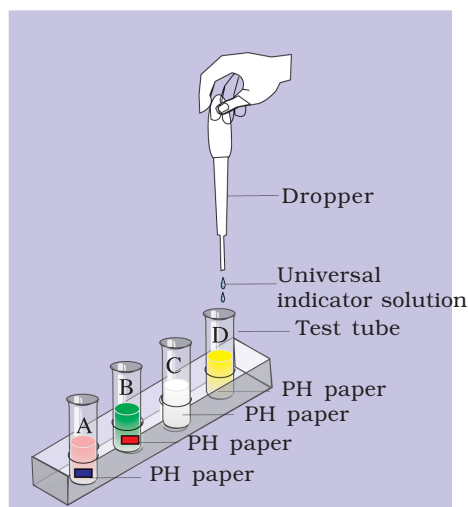

Fig. 10.2.3 Determining pH of given substances using pH paper/universal indicator solution

5. Compare the colour of the solutions of each test tube with the chart paper attached to the universal indicator bottle or pH paper strip, and note the approximate value of pH in the following table.
6. Complete the last column of the table on the basis of your above observations.

Test tube	Solution	Colour of solution with universal indicator/pH paper	Approximate pH value	Nature of solution (acidic/basic/neutral)
A				
B				
C				
D				
E				
F				
G				

**What have you learnt?**

The solutions of HCl,  $\text{CH}_3\text{COOH}$ , lemon juice have pH value of less than 7 and hence, they are acidic in nature. The solutions of tap water, NaOH,  $\text{NaHCO}_3$  have pH value greater than 7 hence, they are basic in nature.

**Extension**

1. Try out the above activity with solutions of coffee, aerated drink, saliva before and after meal, tomato juice and antacid tablets and identify their nature.

Note: In order to prepare Dil. HCl solution, add one drop of Conc. HCl to 50 mL of water. Don't take ordinary Dil. HCl which has pH of about 6. Similarly prepare Dil. NaOH/ $\text{NaHCO}_3$  solutions to have pH in the range of 10-12.

**ACTIVITY 10.2.4 How can you identify bleaching powder, washing soda and baking soda from given samples X, Y and Z?**

**What is required?**

Given samples X, Y, Z, wash bottle, test tubes, rose petals, Dil.  $\text{H}_2\text{SO}_4$  and spatula.

**How will you proceed?**

1. Take three test tubes and label them as A, B and C.

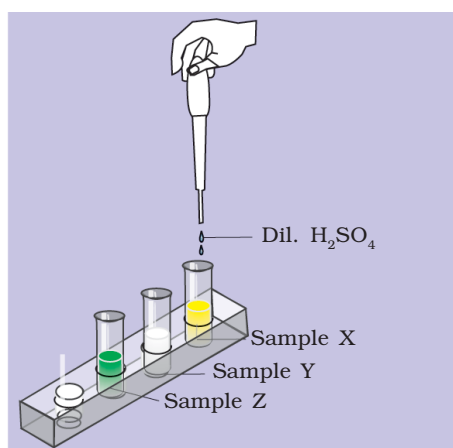

**Fig. 10.2.4.** Identify bleaching powder, washing soda and baking soda from given samples

2. Put the given samples X, Y, Z in the test tubes.
3. Add water to each test tube, touch them and observe carefully. Shake test tubes to dissolve substances.
4. Which samples are completely soluble in water?
5. Sample which gives endothermic reaction with water and is sparingly soluble, is identified as sodium bicarbonate (baking soda).
6. Add a rose petal to the remaining two test tubes and leave them for some time.
7. Add dil.  $\text{H}_2\text{SO}_4$  to each test tube B and C.
8. Does the colour of rose petal remain same? Observe carefully.
9. The test tube in which rose petal gets decolourised contains bleaching power.
10. The third test tube, contains washing soda.

**What have you learnt?**

1. Bleaching powder decolourises the rose petals and their reaction is known as ..... reaction.
2. Sodium bicarbonate gives endothermic reaction with water and is sparingly soluble in water.
3. Washing soda gives exothermic reaction with water and is soluble in water.



**ACTIVITY 10.2.5 How will you show that crystals of copper sulphate contain water of crystallisation?****What is required?**

Test tube, test tube holder, kerosene burner and crystals of hydrated copper sulphate.

**How will you proceed?**

1. Take a few crystals of hydrated copper sulphate in a test tube. Hold it with a test tube holder and note the colour of the crystals.
2. Heat the crystals in the test tube. Is there any change in the colour?
3. Do you observe any water droplets outer inner sides of the test tube side? Where have these water droplets come from?

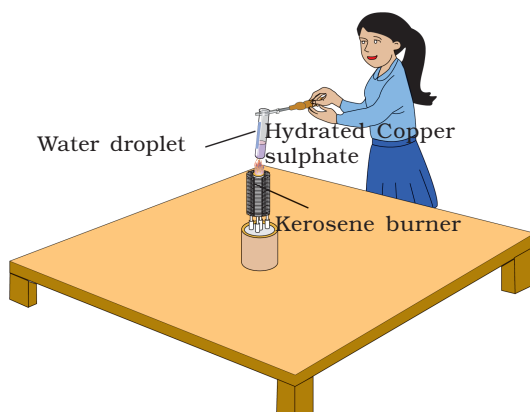

**Fig. 10.2.5** Showing hydrated copper sulphate contains water of crystallisation

4. Now add a few drops of water to the test tube. What colour do you observe and why?

**What have you learnt?**

1. The crystals of  $\text{CuSO}_4$  have water of crystallization present in it.
2. Hydrated  $\text{CuSO}_4$  is blue in colour and anhydrous  $\text{CuSO}_4$  is of white colour.
3. The anhydrous  $\text{CuSO}_4$  turns blue again on adding a few drops of water due to formation of hydrated  $\text{CuSO}_4$ .

**ACTIVITY 10.2.6 How will you prepare SO<sub>2</sub> gas and draw inference in respect of its:**

- (i) effect on litmus paper.
- (ii) action on acidified K<sub>2</sub>Cr<sub>2</sub>O<sub>7</sub>.
- (iii) solubility in water.

Note: Traditional way of preparation of sulphur dioxide requires big apparatus in which a lot of chemicals are wasted. Experimental set up takes lot of time too and sometimes does not succeed. We don't suggest to determining its odour. Fumes of sulphur dioxide pollute the atmosphere. Lot of H<sub>2</sub>SO<sub>4</sub> is drained. We suggest here a simple and non-polluting method.

**What is required?**

Copper turnings, conc. and dil. sulphuric acid, W-tube, potassium dichromate, potassium permagnate, blue and red litmus papers, kersone burner, dropper, beaker, Pasteur pipette, glass dropper, test tube holder and sodium sulphate.

**How will you proceed?**

1. Take a clean and dry W-tube. In one of its arm, transfer some copper turnings.
2. Transfer a few drops of freshly prepared very dil. solution of potassium permagnate with the help of Pasteur pipette in the second arm of W-tube.
3. Transfer a few drops of conc. H<sub>2</sub>SO<sub>4</sub> with the help of glass dropper into the arm containing Cu turnings. Close the end with the dropper. Don't use Pasteur pippette for conc. H<sub>2</sub>SO<sub>4</sub>.
4. Hold the W- tube with test tube holder and heat this end in the flame of the burner gently. What do you observe? Does the pink colour of potassium permagnate solution turn colourless?
5. Clean the W-tube and repeat the experiment, taking now, a few drops of acidified potassium dichromate in place of potassium permanganate. What do you observe?
6. Repeat the experiment putting wet blue litmus and red litmus papers one by one over the other end of the W-tube. What do you observe?
7. Repeat the experiment transferring a few drops of water in

the other arm of W-tubes. Test the water with blue and red litmus paper. What do you observe? Do you find sulphur dioxide soluble in water?

**What have you learnt?**

1. Sulphur dioxide can be prepared by Cu and conc.  $\text{H}_2\text{SO}_4$  and the chemical equation for the reaction is  $\text{Cu}_{(s)} + \text{conc. H}_2\text{SO}_{4(aq)} \rightarrow \text{_____} + \text{_____} + \text{_____}$
2. Sulphur dioxide dissolves in water.
3. Sulphur dioxide decolourises potassium permagnate solution, changes colour of acidified potassium dichromate solution to its reducing properties.

Note: alternatively you can prepare  $\text{SO}_2$  gas by taking a small amount of sodium sulphate in one of the arms of W-tube and by adding a drop of dil.  $\text{H}_2\text{SO}_4$ . Testing the properties of  $\text{SO}_2$  gas is done in the similar way as was done taking Cu turnings/Conc.  $\text{H}_2\text{SO}_4$ .

## 10.3 Metals and Non-metals

### ACTIVITY 10.3.1 How will you compare the physical properties of metals and non-metals?

#### What is required?

Copper strips, aluminium strips, a piece of sulphur, iodine, hammer, clamp stand, kerosene burner, circuit board and sand paper, ( Sulphur powder is not to be used in this experiment).

How will you proceed?

#### Part A

1. Hold the samples of copper, aluminium, sulphur, and iodine, in your hand and try to press them with your fingers.
2. Can they be pressed easily?

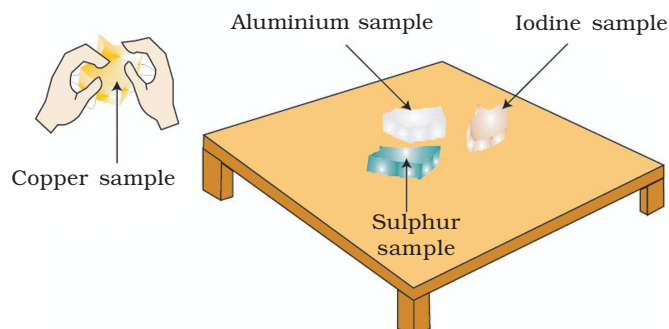

**Fig. 10.3.1(a)** Pressing samples of copper, aluminium, sulphur and iodine

#### Part B

3. Keep the above samples on a flat wooden surface and beat them using a hammer.

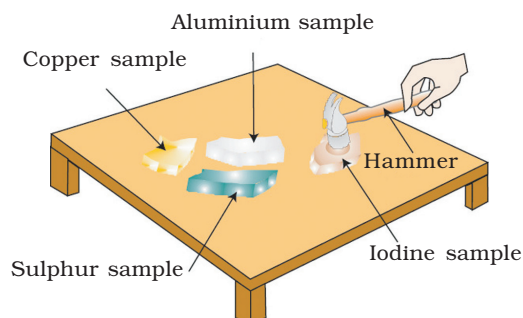
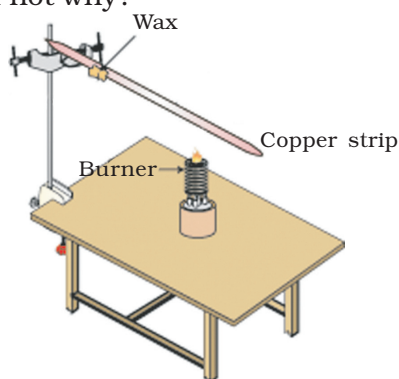

**Fig. 10.3.1(b)** Beating of samples using hammer

4. Which amongst them could be broken into small pieces and which of them started flattening?

*Part C*

5. Clamp the copper and aluminium strips with the help of clamp on the stand. Put a drop of wax on each of them at the end and heat them using a kerosene burner at the other end.
6. What do you observe? Does the wax melt?
7. Do this activity using sulphur and iodine and observe if the wax melts? If not why?



**Fig. 10.3.1(c)** Metals are good conductors of heat

*Part D*

8. Arrange the circuit board assembly as shown in [Fig.10.3.1 (d)] and insert each one of the above four samples under the strips of the tap key one after the other. Observe what happens?
9. Does the bulb glow every time?

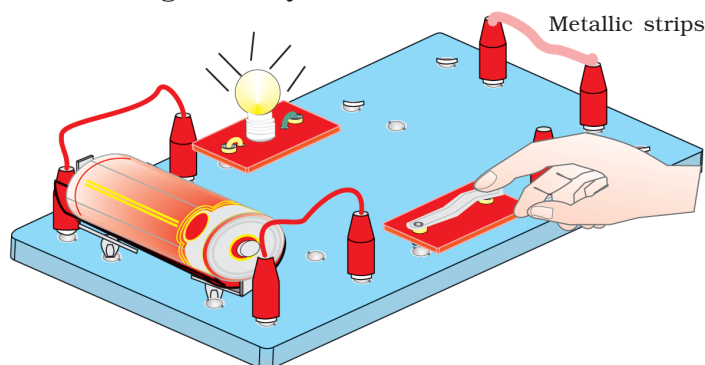

**Fig. 10.3.1(d)** Metals are good conductors of electricity

*Part E*

10. Hold the samples one by one in one hand and strike each of them with a metal spoon.

11. What type of sound is produced from the samples?

*Part F*

12. Rub the surface of copper and aluminium strips using a sand paper.

13. Do you find any change in appearance of the surface before and after rubbing?

14. Can this activity be performed with sulphur and iodine?

Record all of your above observations in the following table.

**Table: Properties of some substances**

Sample	Type of surface after rubbing with sand paper shining/not shining	Hardness can be compressed/not compressed	Beaten in to sheet Yes/No	Conductivity Yes/No Heat/Electricity		Type of sound Ringing/Not Ringing
Copper						
Iodine						
Aluminium						
Sulphur						

**What have you learnt?**

1. Elements like copper and aluminium have shining surfaces, are hard, can be beaten into sheets, conduct heat and electricity and are sonorous. Hence, they are metals.
2. Elements like iodine and sulphur don't have shining appearance, are soft and cannot be beaten into thin sheets, do not conduct heat and electricity and are non-sonorous. Hence, they are non-metals.

**ACTIVITY 10.3.2 How will you study the chemical properties of metals ( by observing their reactions with air, water and acids)?**

**What is required?**

Strips of magnesium, aluminium, zinc, iron, copper, kerosene burner, a pair of tongs, match box, test tube, beaker, blue and red litmus papers, Dil. HCl and W- tube

**How will you proceed?**

1. Rub the surfaces of magnesium, aluminium, zinc, iron and copper strips with sand paper.
2. Heat each of the samples on kerosene burner one by one for 2 minutes while holding these with a pair of tongs.

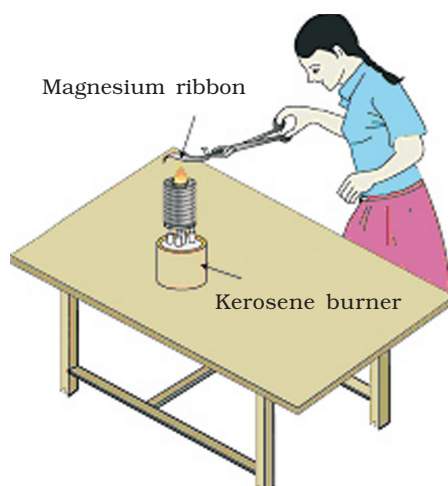

**Fig. 10.3.2(a)** Heating magnesium strip

3. What is the colour of the flame, when these metals are heated?
4. Is there any change in the surface of these metals after heating?
5. Arrange the metals in decreasing order of their activity towards oxygen.
6. Collect the product formed, separately, for each of the samples.
7. Dissolve each of the products formed in water in separate test tubes.
8. Test these solutions with blue and red litmus papers.

9. What is the nature of the solution when metallic oxides are dissolved in water?
10. Write the chemical equations for the above reactions.
11. Put the above samples of metals separately in different test tubes which already contain cold water. Mark them as A, B, C, D and E.
12. Which metals reacted with cold water?
13. Heat test tubes A, B, C, D and E containing metal samples in water. Test this water with blue and red litmus papers.
14. What is the nature of these solutions?
15. Which metals react neither with cold water nor with hot water?
16. Again take the samples of the above metals and rub their surface with sand paper.
17. Put the samples in separate test tubes which contain dil. hydrochloric acid.
18. Observe the rate of formation of bubbles carefully.
19. Which metals react with dil. HCl vigorously?
20. Arrange the metals in decreasing order of reactivity with dil. HCl.
21. Write the chemical equations for these reactions.

**What you have learnt?**

1. Magnesium metal reacts with hot water.
2. Copper metal neither reacts with cold water nor with hot water.
3. Metal oxides are produced when metals are burnt in air and solutions of these oxides in water turn red litmus blue.
4. The order of reactivity of metals with dil. HCl is  $Mg > Al > Zn > Fe$ . Copper does not react with HCl.
5. Hydrogen gas is produced when metals react with dil. HCl.



**ACTIVITY 10.3.3 What is the action of metals such as Zn, Mg, Cu, and Al on their salts? What is the order of their reactivity in such reactions?**

**What is required?**

Strips of zinc, magnesium, copper, and aluminium metals, concentrated aqueous solutions of  $\text{ZnSO}_4$ ,  $\text{MgSO}_4$ ,  $\text{CuSO}_4$ ,  $\text{Al}_2(\text{SO}_4)_3$ , micro test tubes (16 numbers) and micro test tubes stand.

**How will you proceed?**

1. Take a few drops of saturated solutions of  $\text{ZnSO}_4$ ,  $\text{MgSO}_4$ ,  $\text{Al}_2(\text{SO}_4)_3$  and  $\text{CuSO}_4$  in four different test tubes marked as A, B, C and D. Dip thin strip of zinc metal in these test tubes containing solutions of salts of metals, and keep them aside for few minutes. Observe the surface of the dipped zinc metal after taking it out.

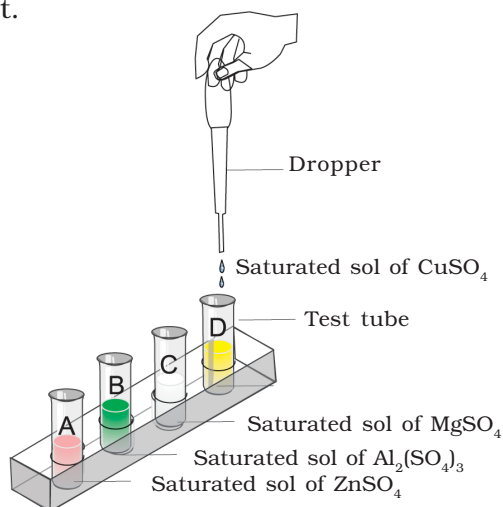

**Fig 10.3.3** The action of metals such as Zn, Mg, Cu, Al on their salts

2. Is there any deposition on the surface of zinc metal in these four test tubes?
3. Is the colour of the deposit formed in different test tubes on the surface of zinc metal same or different?
4. In how many test tubes, there is a deposition on the surface of zinc metal?
5. Repeat the above steps with other metal strips.

6. Observe in which of the test tube, there is a deposition on the surface of the metals?
7. Record your observations in the following table:

<i>Metal</i>	<i>ZnSO<sub>4</sub> solution</i>	<i>MgSO<sub>4</sub> solution</i>	<i>CuSO<sub>4</sub> solution</i>	<i>Al<sub>2</sub>(SO<sub>4</sub>)<sub>3</sub> solution</i>
Zn				
Mg				
Cu				
Al				

Note: Put a '✓' mark if there is deposition on the surface of the metal with the corresponding solution given in the table. Put a '×' mark if there is no deposition.

#### What have you learnt?

1. The metal on which there is deposition from all the three solutions is Magnesium. Hence, it is the most reactive metal amongst the samples studied.
2. The metal on which there is deposition from two solutions is Aluminium. Hence, it is the next reactive metal in series.
3. The metal on which there is deposition from one solution is Zinc. Hence, it is the next reactive metal in the series.
4. The metal on which there is no deposition from any solution is Copper. Hence, it is the least reactive metal out of those which have been studied.
5. So, the decreasing order of reactivity of the given metals is:  
Mg>Al>Zn>Cu

**ACTIVITY 10.3.4 Do ionic compounds dissolve in both polar and non-polar solvents?****What is required?**

Ionic compounds (NaCl and  $\text{CuSO}_4$ ), a polar solvent ( $\text{H}_2\text{O}$ ), a non-polar solvent (Kerosene oil) and test tubes

**How will you proceed?**

1. Take two test tubes and label them as A and B.
2. Take water and kerosene, respectively in these test tubes and add NaCl to each of them.
3. Does NaCl dissolve in both the solvents?
4. Repeat the same procedure with  $\text{CuSO}_4$ .

**What have you learnt?**

Ionic compounds are soluble in polar solvents and are insoluble in non-polar solvents.

**ACTIVITY 10.3.5 Do ionic compounds conduct electricity?****What is required?**

Ionic compound (NaCl), bell jar, double-bored cork, stainless steel electrodes, bulb, two 9V batteries, wires and kerosene oil

(Note: If a 9 V battery is not available, a 6 V battery or four dry cells of 1.5 V fitted in a cell casing may be used)

**How will you proceed?**

1. Take a bell jar, fitted with double bored corks, and fitted with two stainless steel electrodes.
2. Transfer about 20 mL NaCl solution in bell jar.
3. Connect a 9V battery and bulb to the electrodes.
4. Repeat the experiment with kerosene oil in the bell jar.  
Does the bulb glow in both the cases?

**What have you learnt?**

An ionic compound conducts electricity when dissolved in water.

**ACTIVITY 10.3.6 Do moisture and air affect corrosion?****What is required?**

Three test tubes, six iron nails, oil, anhydrous calcium chloride, sand paper and rubber corks

**How will you proceed?**

1. Take three test tubes and label them as A, B and C.
2. Take iron nails and clean their surface with a sand paper.
3. In test tube A, add some water and put two iron nails and cork it.
4. In test tube B, take some boiled distilled water and add few drops of oil and put two nails into it and cork it.
5. In test tube C, put some anhydrous calcium chloride and place two nails in it. Cork it.

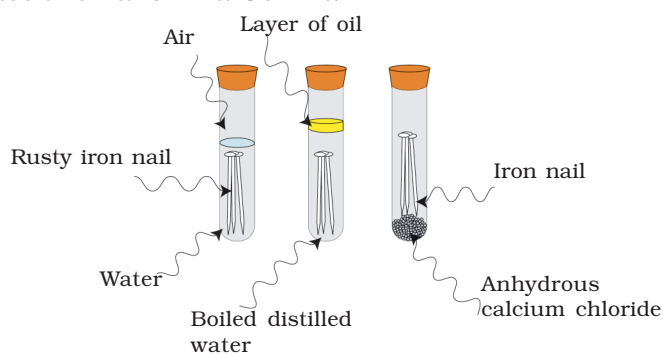

**Fig. 10.3.6** Investigating the conditions under which iron rusts. In test tube A, both air, water are present. In test tube B, there is no air, air dissolve in the water, in tube C, the air is dry.

6. Leave the three test tubes without disturbing for one day and then observe.
7. In which test tube the iron nails get rusted?
8. Why do the nails in the other two tubes do not get rusted?

**What have you learnt?**

1. Rusting takes place in test tube A as there is presence of air and water.
2. Rusting does not take place in test tube B as no air is available.
3. Rusting does not take place in test tube C due to absence of water or moisture.

## 10.4 Carbon and Its Compounds

**ACTIVITY 10.4.1** How will you study the following properties of ethanoic acid (1) odour (2) solubility in water (3) effect on litmus (4) reaction with sodium bicarbonate.

### What is required?

Water, ethanoic acid, sodium bicarbonate, lime water, blue litmus solution, red litmus solution, test tubes, W-tube (you may take red and blue litmus paper instead of red and blue litmus solutions)

### How will you proceed?

1. Take a few drops of ethanoic acid in a test tube and smell it. Can you correlate this smell with any of your food items?
2. Add a few drops of water in this test tube and shake. Is the acid soluble in water?
3. Take two test tubes and label them as A and B. Transfer drop of ethanoic acid in both the test tubes. Transfer a drop of red litmus solution in test tube A and blue litmus solution in test tube B. In which test tube, does the colour of the litmus solution change?
4. In another test tube, take one drop of ethanoic acid and add a small amount of sodium bicarbonate. Is there any effervescence observed? What is it due to?
5. Test the nature of gas by passing it through lime water. Do the test in W-tube.

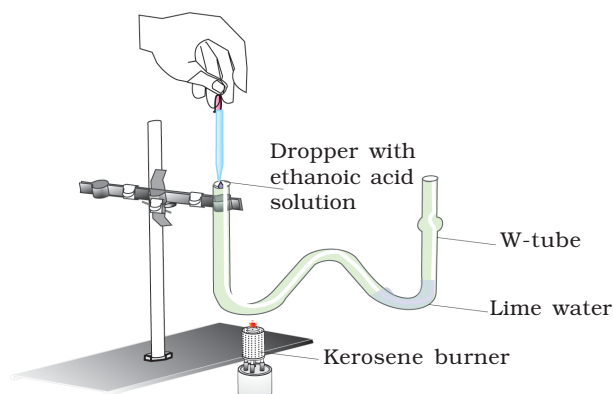

**Fig.10.4.1.** Studying the properties of ethanoic acid in W-tube

**What have you learnt?**

1. Ethanoic acid smells like vinegar and is soluble in water.
2. Ethanoic acid converts blue litmus to red.
3. On addition of sodium bicarbonate to ethanoic acid, evolution of  $\text{CO}_2$  gas takes place.

**ACTIVITY 10.4.2 How do ethanol and ethanoic acid react with each other in the presence of conc.  $\text{H}_2\text{SO}_4$ ?****What is required?**

Ethanol, ethanoic acid, conc.  $\text{H}_2\text{SO}_4$ , test tube, beaker (10 mL), kerosene burner, tripod stand, aqueous solution of  $\text{NaHCO}_3$ . (If ethanol is not available, take rectified spirit)

**How to proceed?**

1. Take a few drops of ethanol in a clean test tube. Smell it.
2. Add an equal number of drops of ethanoic acid to the test tube. What is the smell of ethanoic acid?
3. Add one drop of conc.  $\text{H}_2\text{SO}_4$  to the reaction mixture.
4. Take a beaker (10 mL), fill it about half with water and heat it on a kerosene burner on a tripod stand.
5. Now place the test tube containing the reaction mixture in the beaker and heat it for some time.
6. Take out the test tube and smell the vapours coming out.
7. Is there any difference in the smells of ethanol, ethanoic acid, and the reaction mixture after heating?
8. Pour the reaction mixture into another beaker containing an aqueous solution of  $\text{NaHCO}_3$ .
9. Smell the liberated vapours from the beaker.

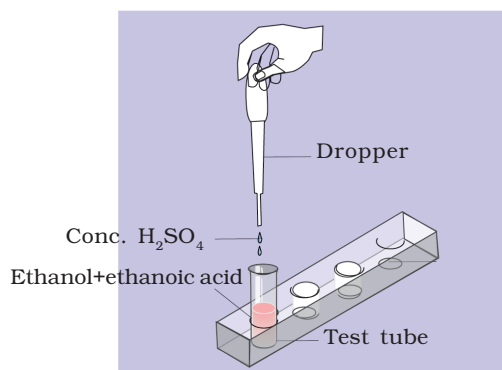

**Fig.10.4.2** Reaction of ethanol and ethanoic acid with each other in the presence of conc.  $\text{H}_2\text{SO}_4$

10. What is the smell of the vapours?
11. Is it the same as it was coming out before pouring into  $\text{NaHCO}_3$  solution?
12. Can you tell why this type of smell produced is?



13. Why have we poured the reaction mixture in aqueous  $\text{NaHCO}_3$  solution?

**What have you learnt?**

1. Ethanol reacts with ethanoic acid in the presence of conc.  $\text{H}_2\text{SO}_4$  to form a fruity smelling compound.
2. The compound formed is known as an ester and the reaction is called as esterification reaction.
3. The equation for the above reaction is:

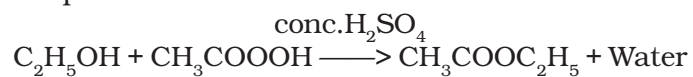

**ACTIVITY 10.4.3 What happens when alkaline solution of potassium permanganate is added to alcohol?****What is required?**

Ethanol, alkaline potassium permanganate solution, dropper, kerosene burner, test tubes, test tube holder, water bath.

**How will you proceed?**

1. Take 4 drops of ethanol in a test tube and heat it gently.
2. Add dilute solution of alkaline potassium permanganate drop by drop to the test tube.
3. Does the colour of alkaline potassium permanganate persist?
4. Why does the colour of potassium permanganate disappear?
5. Can you write the chemical equation for this reaction?

**What have you learnt?**

Ethanol reacts with alkaline potassium permanganate.

**ACTIVITY 10.4.4 How will you test hard water by using**

## soap and detergent solutions?

### What is required?

Test tubes, test tube stand, hard water, soap solution and detergent solution

### How will you proceed?

1. Take two test tubes and label them A and B.
2. Add a small amount of hard water in both the test tubes. Add a few drops of soap solution in test tube A.
3. Add an equal volume of the detergent solution in test tube B.

**Fig.10.4.4** Testing of hard water using soap and detergent

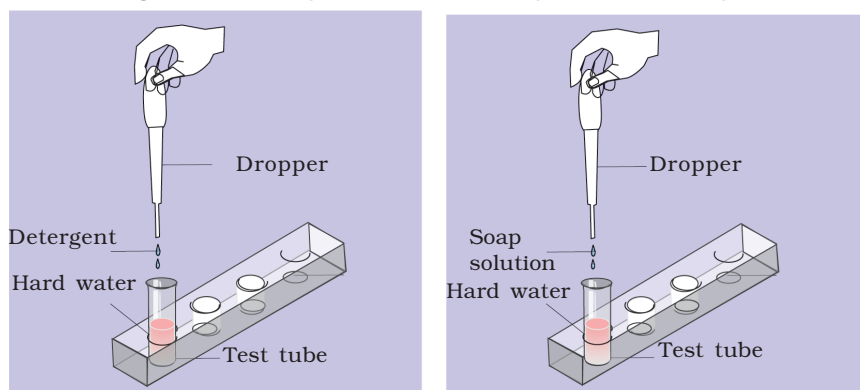

4. Shake these test tubes for equal time. Compare the amount of foam formed in each test tube. In which of test tubes greater amount of foam is formed.

### What have you learnt?

The foaming capacity of detergent is much more than that of soap in hard water.

### ACTIVITY 10.4.5 How will you compare the foaming

**capacities of soap in hard water and distilled water?****What is required?**

Test tubes, test tube stand, distilled water, hard water and soap solution

**How will you proceed?**

1. Take two test tubes and label them A and B.
2. Add some distilled water in test tube A.
3. Add equal volume of hard water in test tube B.
4. Add equal number of drops of soap solution to both the test tubes.
5. Shake these test tubes for equal time. What do you observe? Compare the amount of foam formed in each test tube. In which test tube foam is formed?

**What have you learnt?**

1. The foaming capacity of soap in distilled water is much more than that in hard water.

## 10.5 Life Process

### ACTIVITY 10.5.1 How to study stomata?

Stomata are the minute pores on epidermal layer of leaves of plants, and are meant for exchange of gases and transpiration.

#### What is required?

Slides cover slips, needle, brush, blade, compound microscope, dicot (*Bryophyllum*, *Hibiscus*, etc.) and monocot (lily, *Rhoeo* etc.) leaves, safranin, glycerine

#### How to proceed?

1. Remove the lower epidermal layer of a leaf by breaking and pulling along gently using needle.
2. Cut a small piece of the peel and place it on a slide in a drop of safranin, wash with water and mount in glycerine.
3. Place a cover slip gently.
4. Observe the slide under low power microscope and count the number of stomata and epidermal cells in the microscopic field.
5. Repeat all the steps of same experiment with leaf peels of other plants.

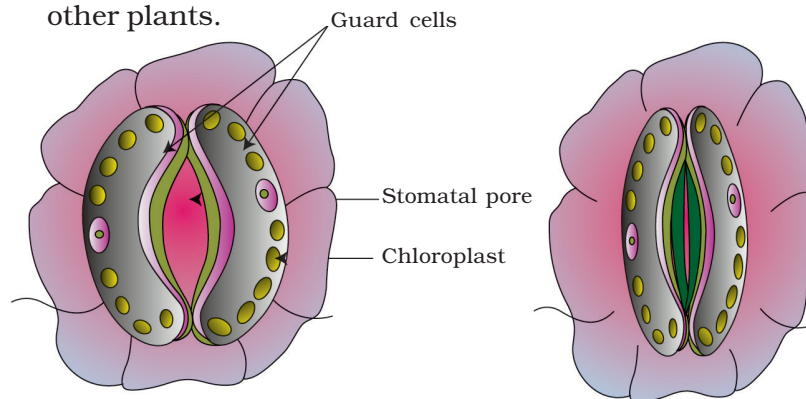

Fig. 10.5.1 Structure of a stomata

#### What have you learnt?

1. Stomata are in the form of pores/openings surrounded by two guard cells.

2. In monocots, stomata are present on both upper and lower epidermis but in dicots, stomata are present on the lower epidermis only.

**Extension**

Spread a thin layer of transparent nailpolish/quickfix on the surface of leaves. Allow it to dry. Remove the dried layer gently. Put it on a slide and observe the impression of stomata under the microscope.

**Precautions**

1. The staining of the peel should be adequate.
2. Cover slip should be placed gently with the help of a needle so as to avoid air bubbles and folding of epidermal peel.

### ACTIVITY10.5.2 How to demonstrate the role of light in photosynthesis?

The process of preparing food by green plants requires sunlight for the splitting of water molecule.

#### What is required?

Black paper, Petri dish, beaker, test tube, dropper, clips, iodine solution, rectified spirit, kerosene burner, potted plant with thin leaves (*Balsam*, *Petunia*, *Dracaena*, etc)

#### How to proceed?

1. Destarch the potted plant by placing it in dark for about 72 hrs.
2. Using strips of black paper and clips cover part of one leaf [Fig.10.5.2a].
3. Now place the experimental set up (potted plant with covered black strip) under sunlight for about a day.
4. Pluck the leaf which was covered. Remove the black strips.
5. Boil the leaf in water for about 5 min and let it cool.
6. Transfer the leaf carefully to a test tube containing rectified spirit.
7. Place the test tube in a beaker containing water and boil till the leaf get decolourised [Fig.10.5.2b].
8. Wash the decolourised leaf carefully with tap water.
9. Place the leaf in a Petri dish, pour iodine solution on the leaf and observe [Fig.10.5.2c].

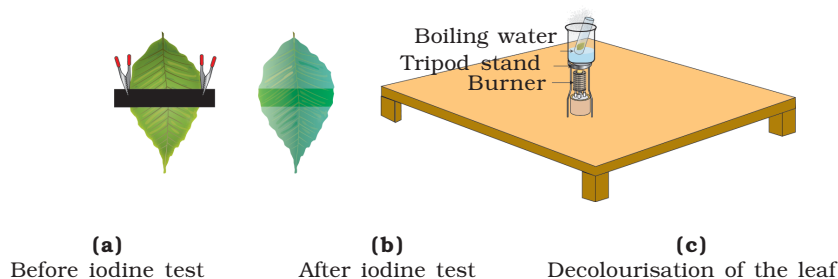

**Fig.10.5.2** Preparing the leaf for iodine solution

**What have you learnt?**

1. The covered area of the leaf will not show any colour change on addition of iodine solution because no starch is formed. This shows that photosynthesis has not taken place in the absence of sunlight.
- 2 The uncovered area of the leaf, which was exposed to sunlight turned blue-black on addition of iodine solution. This is due to the formation of starch during photosynthesis.



### ACTIVITY 10.5.3 How to demonstrate importance of carbon dioxide in photosynthesis?

Plants use  $\text{CO}_2$  to prepare starch during the process of photosynthesis.

#### What is required?

Conical flask of capacity 25 mL, cork, test tube, thread, potassium hydroxide (solution), rectified spirit, iodine solution, petroleum jelly, water and potted plant with long leaves

#### How to proceed?

1. Destarch the potted plant by placing it in dark for about 72 hrs.

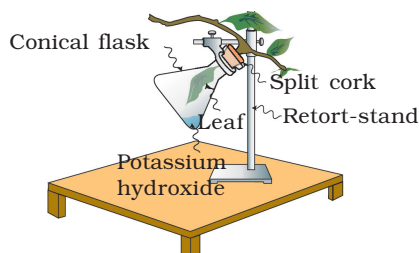

**Fig. 10.5.3** Carbon dioxide is necessary for photosynthesis

2. Put 10 mL solution of potassium hydroxide in a 25 mL conical flask.
3. Insert half of an intact leaf of the destarched plant into the flask containing KOH solution through split cork fixed onto a stand. The cork should be made air tight by applying petroleum jelly.
4. Keep the set up in bright sunlight for about a day.
5. Remove the leaf from the flask and perform iodine solution test.

#### What have you learnt?

The portion of the leaf that was inside the flask will not show any colour change with iodine solution. This is because KOH absorbed  $\text{CO}_2$  inside the air of the flask. Hence, no photosynthesis took place in the absence of  $\text{CO}_2$

#### Precautions

1. Destarch the plant properly.
2. Cork should be fitted air tight and sealed with petroleum jelly.

**ACTIVITY 10.5.4 (a) How to demonstrate liberation of carbon dioxide gas during respiration in human beings?**

Majority of living organisms require oxygen for breakdown of food and in the process they liberate energy and carbon dioxide.

**What is required?**

Test tube, straw, freshly prepared lime water

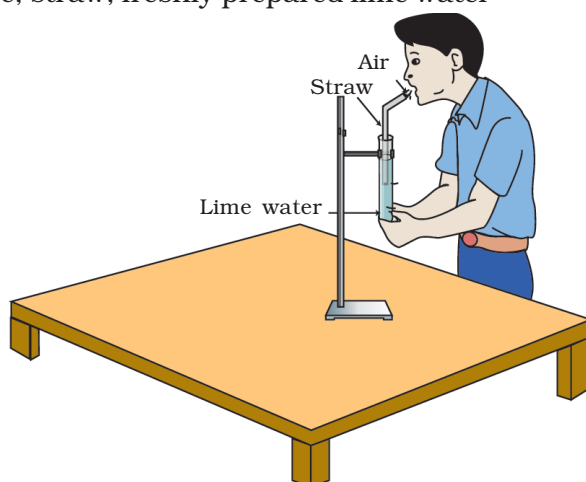

**Fig.10.5.4(a)** Demonstration to show liberation of  $\text{CO}_2$  gas during respiration in human beings

**How to proceed?**

1. Take a test tube which is half filled with freshly prepared lime water.
2. With the help of a straw, blow air into the lime water.
3. Observe the colour change.

**What have you learnt?**

The lime water turns milky due to  $\text{CO}_2$ .

**Precaution**

Lime water should be prepared a fresh every time.

**ACTIVITY 10.5.4(b) How to demonstrate liberation of carbondioxide gas during respiration in plants?****What is required?**

Boiling tube/Test tube with a bored cork, glass tube, KOH solution, cotton, safranin, forceps and germinating seeds of *moong/mustard/gram*, petroleum jelly

**How to proceed?**

1. Insert glass tube into the bored cork.
2. Put some germinating seeds at the bottom of the test tube.
3. Place the tube horizontally on the table.
4. Hold some cotton in a forceps and dip it in KOH solution.
5. Place it gently in the middle part of horizontally placed test tube.
6. Now fix the cork with the glass tube in the mouth of the test tube and make it airtight using petroleum jelly.
7. Gently introduce a drop of safranin from the open end of the glass tube.
8. Leave the set up undisturbed on the table.
9. Observe the movement of the safranin drop in the glass tube.

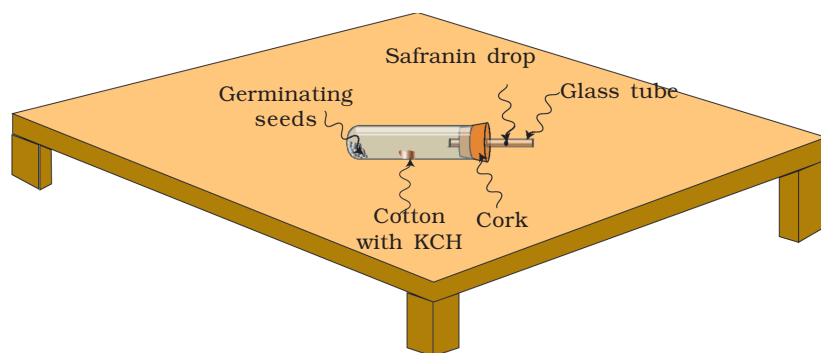

**Fig.10.5.4 (b)** Demonstration of liberation of CO<sub>2</sub> gas during respiration in plants

**What have you learnt?**

1. The germinating seeds are taking up oxygen and releasing CO<sub>2</sub> during respiration.

2. The  $\text{CO}_2$  hence released is absorbed by KOH.
3. This creates a partial vacuum in the test tube.
4. The force thus created due to vacuum pulls the safranin drop towards the test tube.

**Precaution**

1. Set-up must be kept horizontally on the table.
2. The cotton with KOH solution should never touch the germinating seeds.

**Extension**

This activity can also be done with flower buds and small fruits.

**ACTIVITY 10.5.5 How to demonstrate the production of CO<sub>2</sub> during anaerobic respiration?**

During anaerobic respiration, the food material breaks down into CO<sub>2</sub> and alcohol in the absence of air (O<sub>2</sub>) by microorganisms such as yeast.

**What is required?**

Sugar solution (15-20%), test tubes, delivery tube, one holed cork, freshly prepared lime water petroleum jelly and yeast.

**How to proceed?**

1. Fill the test tube completely with sugar solution.
2. Dissolve some granules of yeast in warm water in a test tube and mix it well.

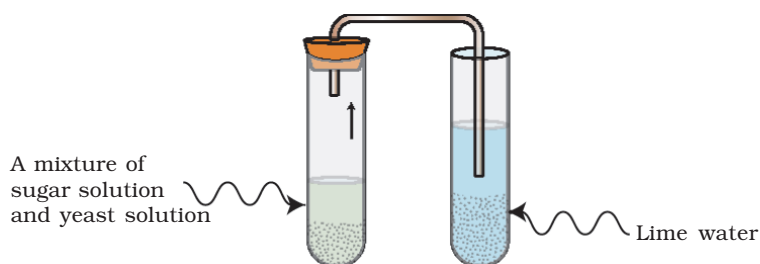

**Fig. 10.5.5** Demonstration of the production of CO<sub>2</sub> gas during anaerobic respiration

3. Add about 20 drops of yeast solution to sugar solution.
4. Using petroleum jelly, fix a cork tightly with a delivery tube bent twice at right angles.
5. Place the other end of delivery tube in a test tube containing freshly prepared lime water.
6. Observe what changes are caused in the colour of lime water with time.

**What have you learnt?**

The colour of lime water becomes milky due to the CO<sub>2</sub> released during anaerobic respiration by yeast.

**ACTIVITY 10.5.6. How to observe the effect of salivary amylase on food?**

Starch present in food is broken into simpler sugars by the action of amylase present in saliva.

**What is required?**

Test tube, funnel, cotton, iodine solution, wheat flour (*Aata*)

**How to proceed?**

1. Collection of saliva (wash your mouth with water and think of some tasty food item. Enough saliva will be collected in your mouth).
2. Filter the saliva through a cotton swab and collect 1 mL in a test tube. Add 10 mL of water to the saliva to make it saliva solution.
3. Mix wheat flour in water and filter to make starch solution.
4. Take 5 mL of starch solution in two test tubes labelled as A and B.
5. To test tube A, add 1 mL of saliva solution and to test tube B, add 1 mL of water and mix thoroughly.
6. Add 1 or 2 drops of iodine solution in both the tubes after 10 min.
7. Observe the colour change immediately.

**What have you learnt?**

1. The colour in test tube A disappears slowly due to conversion of starch into simple carbohydrates (sugar).
2. The colour in test tube B remains unchanged.

**Extension**

Chew food (chapati/ rice) and note change in taste from tasteless to sweet. Do you think that your chapati/rice has become sweeter?

**Precaution**

1. Filtered saliva should be free from food particles.
2. Before collection of saliva, wash mouth thoroughly with water.

**ACTIVITY 10.5.7 How to demonstrate the process of absorption (imbibition)?**

Cellulosic and sugary materials absorb water, swell and gain weight due to imbibition.

**What is required?**

Petri dish, balance, water, raisins with stalk

**How to proceed?**

1. Take about 10 raisins with stalk and find their initial weight ( $M_1$ ).
2. Soak the raisins in water for about 2 hrs.
3. Take out the raisins and keep them on blotting paper to remove excess water.
4. Weigh the raisins again ( $M_2$ ) and find the difference between  $M_2$  and  $M_1$ .
5. The percentage of water imbibed =  $\frac{(M_2 - M_1)}{M_1} \times 100$

**What have you learnt?**

The swelling in raisins is due to absorption of water through cellulosic membrane.

**Extension**

Repeat the activity with a small piece of wood.

**Precaution**

1. Care should be taken to select raisins with stalk.
2. Raisins must be immersed completely in water.
3. Excess water should be removed before taking final weight of raisins.

## 10.6 Control and Coordination

### ACTIVITY 10.6.1 (a) How to demonstrate phototropism in plants?

#### What is required?

Small disposable plastic cups, seeds of *gram* or *moong*, garden soil, an empty cardboard box like a shoe box

#### How to proceed?

1. Soak some seeds of *gram*/*moong* in water for one day.
2. Pierce a few small holes at the bottom of the disposable plastic cup for drainage of excess water.
3. Fill the cup three fourths with soil.
4. Put some soaked seeds on the soil and cover them by sprinkling a little soil over them.
5. Water the seeds.
6. Put the cup in a shoe box in which a hole of 2 cm diameter has been made on one side. Cover the box with the lid.
7. Put the box in a window or a place where light can fall on the box.
8. Open the box after a week.
9. Observe the growing seedlings.

#### What have you learnt?

The shoots of the seedlings are all bent towards the hole in search of light. That is because the shoot grows towards light and exhibits phototropism.

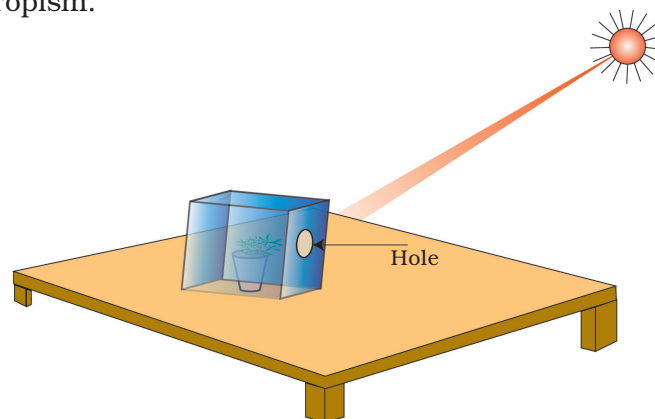

**Fig.10.6.1. (a)** Demonstration showing the phototropism in plant



**ACTIVITY 10.6.1 (b) How to demonstrate geotropism in plants?****What is required?**

Small disposable plastic cups, garden soil, seeds of *gram* or *moong* and two pieces of wooden stand and black paper

**How to proceed?**

1. Soak some seeds of *gram* or *moong* in water for one day.
2. Pierce slightly big holes (2 mm diameter) at the bottom of the cup.
3. Fill it with 1 cm thick layer of garden soil.
4. Sprinkle soaked seeds (*moong/gram*) over the soil. Water the seeds.
5. Put the cup on 2 pieces of wooden or stone slabs so that there is a little gap between the top of the table and bottom of the cup.
6. Cover the lower part of the setup with black paper.
7. Water the seeds regularly with little water.
8. Observe the bottom of the cup after 10 days.



**Fig. 10.6.1 (b)**  
Demonstration showing  
the geotropism in  
plants

**What have you learnt?**

The roots come out from the holes and grow towards the earth showing positive geotropism.

**Extension**

Make a transparent cup by cutting the lower half of a mineral water bottle. Fill it half with soil. Place some soaked seeds towards the wall of the cup, water the seeds. When the seeds germinate, observe the direction of the root and shoot of the seedlings. The roots grow downwards and shoots grow upwards. Now keep the cup in horizontal position for a few days. You will see that the roots bend downwards and the shoots bend upwards.

## 10.7 How do Organisms Reproduce

### ACTIVITY 10.7.1 How to observe organisms multiplying by asexual reproduction?

Organisms can also reproduce without the fusion of gametes by the process of asexual reproduction.

#### What is required?

Permanent slides of *Paramecium* and *Amoeba* for binary fission, and yeast and *Hydra* for budding, microscope.

#### How to proceed?

1. Focus the permanent slides of the mentioned organisms one by one under the microscope. Draw their labelled diagrams.
2. Compare the processes of binary fission and budding.

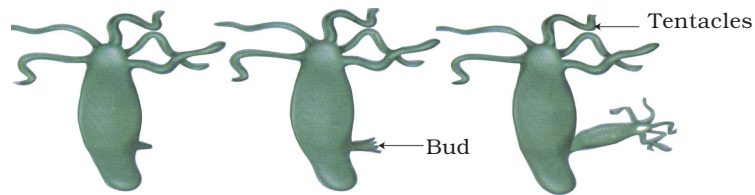

(a) Budding in *hydra*

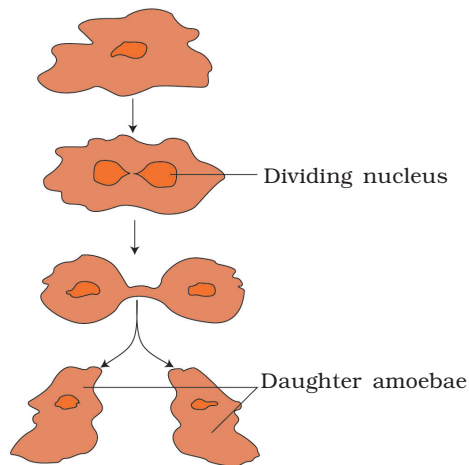

(b) Binary fission in *Amoeba*

**Fig.10.7.1** Asexual reproduction in (a) *Hydra* (b) *Amoeba*

**What have you learnt?**

In binary fission, the entire organism divides into two, while in budding, buds appear from the sides of the organism.

**Extension**

Observe permanent slides showing asexual reproduction in other organism like fungi, bryophytes, etc.

**ACTIVITY 10.7.2 How do some plants propagate vegetatively?**

Vegetative parts of some plants like leaves, stem, etc have the power of regeneration into a new plant.

**What is required?**

Pieces of potato with buds called “eyes”, ginger, turmeric with nodes and internodes, leaves of *Bryophyllum*

**How will you proceed?**

1. Take a *Bryophyllum* leaf and put it in loose manure-rich soil.
2. Water the soil as per requirements.
3. Observe the shoots emerging from the margin of the leaf in about 15 days.
4. This activity can be performed with other materials listed above.

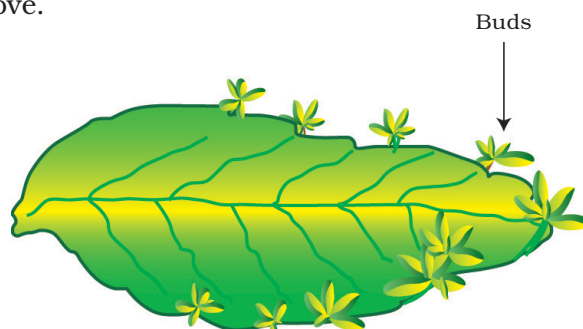

**Fig.10.7.2** *Bryophyllum* leaf producing buds

**What have you learnt?**

The plants can regenerate from their vegetative parts. This property can be used for vegetative propagation of useful plants.

**Extension**

Observe the methods of propagation of rose, canna, banana, etc., being used by the school gardener.

**ACTIVITY 10.7.3 How to study different parts of flower and their role in sexual reproduction.**

Sexual reproduction in angiosperms is performed by specially modified shoot called flower.

**What is required?**

Flowers of any plant like *Petunia*, *Ipomoea*, *Solanum*, *Datura*, *Mustard* etc. forceps, blotting paper, slides, cover slips, blade, and microscope

**How will you proceed?**

1. Place a wet blotting paper (A4 size) on a board.
2. Separate different whorls of a flower with forceps.
3. Arrange the parts of flower on the wet blotting paper in a sequence, like calyx (group of sepals), corolla (group of petals), and roecium (male reproductive part) and gynoecium (female reproductive part).
4. Label the parts separately.
5. Cut transverse sections of the ovary and mount in a drop of water. Observe under the microscope, and count the number of compartments (these are called locules) and ovules.
6. Repeat the above activity with different flowers.

**What have you learnt?**

1. The number and shape of sepals, petals, stamens and carpels vary in different plants.
2. The pollen grains are present in another locules and ovules are located in the ovary.

**Extension**

Compare the structure and mode of reproduction organs in incomplete unisexual flowers like cucurbits, castor etc.

## 10.8 Heredity and Evolution

### ACTIVITY 10.8.1 How to compare homologous and analogous organs in plants and animals?

The organs which have similar origin and structure but may perform different functions are homologous. The organs which have different origins and structures but may perform same function are analogous.

#### What is required?

Sweet potato, potato, cactus phylloclade, tendrils of pea, *Cucurbita* and grapes. Charts showing limbs of frog, lizard, bird, human and bat

#### How will you proceed?

Arrange the above mentioned material as homologous and analogous.

#### What have you learnt?

##### *Homologous*

Tuber of potato, runner of lawn grass and rhizome of ginger represent a stem.

Potato tuber stem for storage.

Cactus phylloclade stem for protection.

*Cucurbita* tendril stem for support.

Limbs of frog, lizard, bird and human for locomotion.

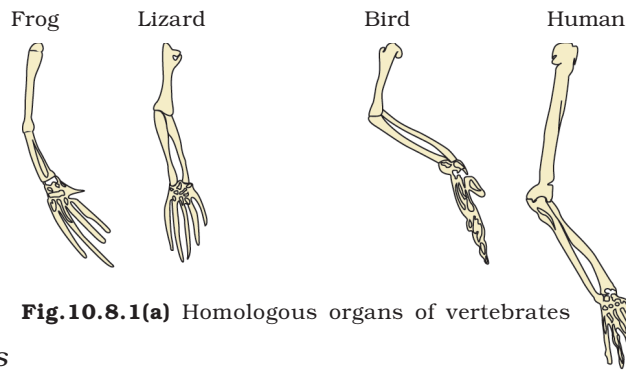

**Fig.10.8.1(a)** Homologous organs of vertebrates

##### *Analogous*

Tuber of potato is stem where as tuber of sweet potato is root.

Sweet potato root for storage.

Garden Cucurbita stem tendril for support.  
Pea leaflets tendril for support.  
Limbs of bird and bat for locomotion.

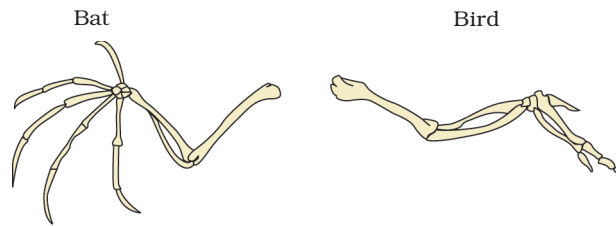

**Fig.10.8.1(b)** Analogous organs

**ACTIVITY 10.8.2 How to study distribution of hereditary characters?**

Characters/traits that are inherited from parents and passed to the offsprings are known as hereditary characters.

**How to proceed?**

1. Observe ears of all the students in your class and identify the students with free or attached ear lobes.
2. Correlate the ear lobe type of each student with that of his/her parents and find one pattern of inheritance.
3. Repeat with observation of traits like rolling of tongue, widows peak, etc.

**What have you learnt?**

The characters present in offsprings are inherited from parents but traits may show variation as compared to parents.



## 10.9 Reflection and Refraction

**ACTIVITY 10.9.1** How do we observe the image formed by:

- (i) *concave*
- (ii) *convex reflecting surfaces?*

**What is required?**

A large shining spoon and a candle

**How will you proceed?**

1. Hold the spoon near a candle flame (not bigger than 1 cm) with its depressed side (i.e., concave side) towards the flame. Are you able to see image of full flame in the depressed surface of the spoon?
2. Move the spoon slowly away from the candle flame and see how does the image change?
3. Turn the spoon so that its bulged side is towards the candle. See the image in the bulged surface (i.e., convex surface) of the spoon, by keeping it near the candle. Can you see full flame now? How is this image different from the image seen in concave side?
4. Now move the spoon slowly away from the flame and observe how does the image change?

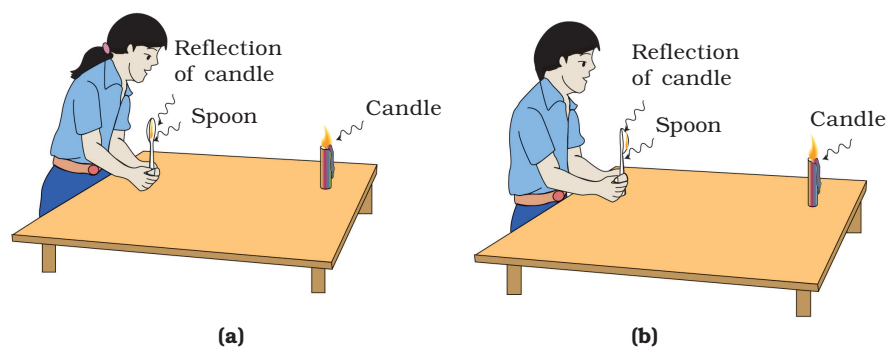

**Fig.10.9.1** Image formed by (a) Concave and (b) Convex shining surfaces of spoon

**What have you learnt?**

1. When an object is placed very near to a concave reflecting

surface, it's erect and magnified image is seen in it. As the object moves away a stage comes when the image formed by the reflecting surface becomes inverted.

2. When an object is placed very near to a convex reflecting surface, its erect and diminished image is seen in it. As the object moves away from the mirror, the image formed in it remain erect but its size decreases gradually.

**Extension**

Repeat this activity by using concave and convex mirror from the kit.

### ACTIVITY 10.9.2 What happens when Sun rays are focused by a concave mirror on a piece of paper?

#### What is required?

Concave mirror ( $f = 10$  to  $15$  cm and diameter atleast half of  $f$ ) and thin black paper or carbon paper

#### How will you proceed?

1. Place a piece of a black paper on table in open and the concave mirror in the hand.

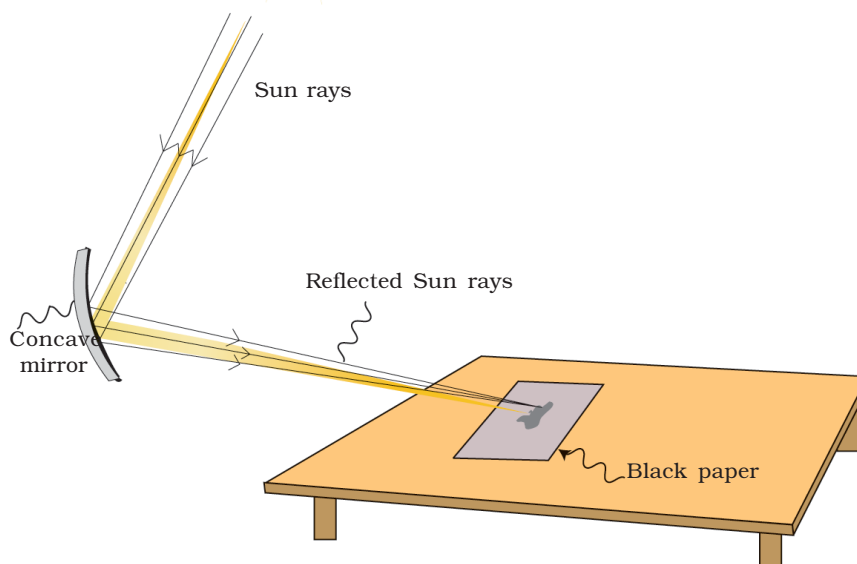

**Fig. 10.9.2** Sun rays focused by a concave mirror on a piece of paper

2. Adjust the position of your hands in such a way that the Sun rays fall on paper after reflection from the mirror.
3. Adjust the position of the paper so that the Sun rays are falling in a focused manner.
4. Hold the mirror and the paper in this position steady for some time.

What do you observe? Why does the paper start burning?

#### What have you learnt?

1. Image of the Sun formed by a concave mirror is real.
2. A concave mirror can concentrate Sun rays almost at a point.

3. The focussed image of the Sun can burn the paper because it also focuses heat along with Sun rays.

Warning: Sun is very bright. Direct looking at Sun may be harmful for our eyes, as the eye lens may focus Sun rays on the retina.

### ACTIVITY 10.9.3 How can the image of a lighted candle formed by concave mirror be studied?

#### What is required?

A concave mirror ( $f=10$  to  $15$  cm), a candle, a screen mounted on a stand and a half metre scale

#### How will you proceed?

1. Find the approximate focal length of the concave mirror as in Activity 10.9.2.
2. Now, draw a straight line on the table. Put a mark O at its one end and mark points at distance  $f$  and  $2f$  from O.

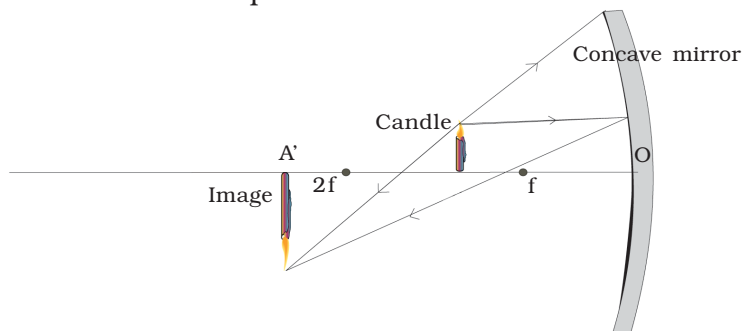

**Fig.10.9.3** Image of a candle formed by concave mirror

3. Place on this line the mirror in stand at O and lighted candle between  $f$  and  $2f$ . Place the screen beyond  $2f$  and move it along the line to obtain a sharp and clear image of the flame of the candle on the screen. Observe the nature, position and relative size of the image. Is the image erect or inverted? Is the image magnified or diminished?
4. Repeat Step 3 by placing the candle at  $2f$  [See note below].
5. Place the candle beyond  $2f$  and try to obtain the image of the flame on the screen by placing it between  $f$  and  $2f$ .
6. Try to obtain image on the screen when candle is placed at  $f$  and also when it is between  $f$  and mirror.

Note: When the candle is at  $2f$  or beyond  $2f$ , it is necessary to shift it a little away from principal axis of mirror, on one side [Fig.10.9.3]. The screen has to be a thin strip, shifted a little on other side of the principal axis. If both are kept on the principal axis, light of candle is prevented by screen from reaching the mirror.

**What have you learnt?**

1. The characteristics of image formed by a concave mirror depend on the position of the object with respect to the mirror.
2. When an object is placed anywhere between  $f$  and infinity, the image formed is real and inverted. But when the object is placed between  $f$  and mirror it can not be obtained on the screen. The image formed in this case is virtual, erect and enlarged. Such image may be seen by looking in the mirror directly.
3. As the object is moved from focus towards infinity, the image moves from infinity towards focus and its size decreases.
4. When object is placed at  $2f$  image of the same size is formed at  $2f$ , itself.

### ACTIVITY 10.9.4 How can the characteristics of the image formed by a convex mirror be studied?

#### What is required?

A convex mirror ( $f = 10$  to  $15$  cm), a screen mounted on a stand and a candle

#### How will you proceed?

1. Hold a convex mirror on a stand with its reflecting surface vertical.

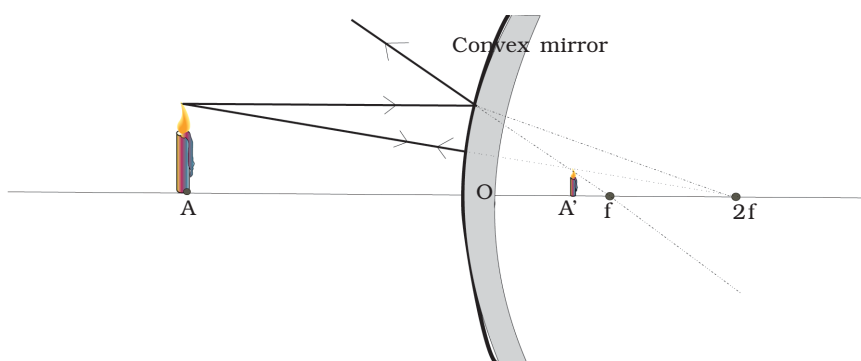

**Fig.10.9.4** Image formed by a convex mirror

2. Bring a lighted candle close to the reflecting surface of the convex mirror and try to obtain the image of the candle formed by the mirror on the screen. Why can't you get the image of the candle on the screen? Now look for the image in the mirror directly and answer the following questions.
  - (a) Is the size of the image smaller than, larger than or equal to the size of the object?
  - (b) Is the image erect or inverted?
3. Repeat the Step 2 by moving the candle away from the mirror in steps of about 5 cm and see how does the size and nature of the image change.

#### What have you learnt?

1. Image formed by a convex mirror is always (a) virtual, (b) erect; and (c) smaller in size than the object,
2. The size of the image decreases as the object is moved away from the mirror.

**ACTIVITY 10.9.5 How can the image of an object formed in a plane mirror be studied?****What is required?**

A plane mirror, a candle, screen mounted on a stand and mirror stand

**How will you proceed?**

1. Hold the plane mirror in your hand as steady as you can and try to observe in the image of a candle flame kept at about 2 m from the mirror.
2. Do you see the full image of the flame in the mirror?
3. Try to obtain this image on the screen by placing the screen behind the mirror. Why could you not obtain the image on the screen?
4. Again observe the image to answer the following:
  - (a) What is the size of the image? Is it enlarged, diminished or equal to the size of the flame?
  - (b) Is it inverted or erect?

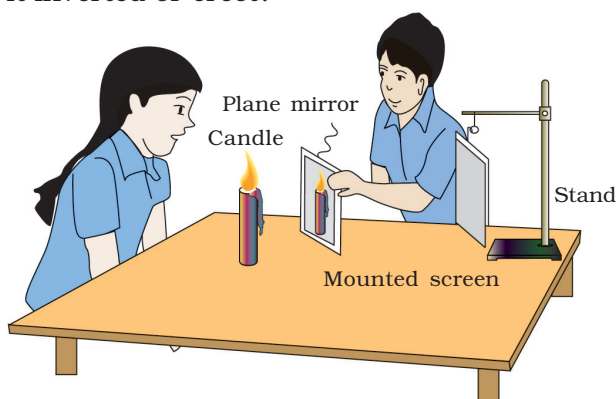

**Fig.10.9.5** Image formed by using a plane mirror

5. Move the mirror first towards the flame, and then away from it. Do you notice any change in the (i) size of the image; and (ii) distance of the image from the mirror?

**What have you learnt?**

A plane mirror forms a virtual and erect image of an object. Image is of the same size as the object and is located as far behind the mirror as the object is in front of it.



### ACTIVITY 10.9.6 How can refraction of light through a rectangular glass slab be studied?

#### What is needed?

A rectangular glass slab, a drawing board, sticking tape, ordinary pins, sewing needles (6 – 7 cm long), thin bamboo sticks, drawing sheet, sharp pencil and scale

#### How will you proceed?

1. Fix a drawing sheet on the drawing board with the help of sticking tape.
2. Draw the boundary of the glass slab after putting it in the middle of the sheet.
3. Place a thin needle/thin bamboo stick A and B such that line passing through them touches the boundary of the glass slab at a point and is inclined to it at some angle (say about 40 degree) as shown in the [Fig.10.9.6].

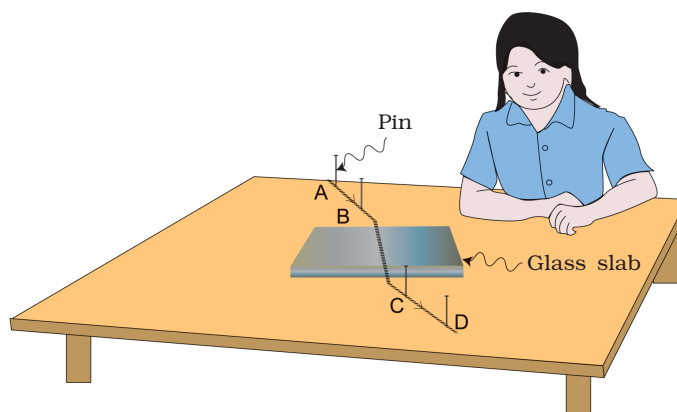

**Fig.10.9.6** Refraction through a glass slab

4. Look at the image of the needle placed at A and B from the opposite side of the slab and put needle at C and D in such a way that it is in straight line with image of needle placed at A and B as seen through the glass slab.
5. Mark both the end of both the needle with pencil and remove the glass slab after that.
6. Join the pencil mark and extend the two lines to meet the boundary of the slab. These two lines represent respectively the incident ray and the emerged ray [Fig10.9.6].

7. Are the lines AB and CD obtained by joining these points (or the incident and the emergent rays) along the same straight line?
8. Produce the first line AB (the incident ray) till it emerges out of the slab?
9. Measure the perpendicular distance between this line and the second line (emergent ray).
10. Join BC. This line represents path of the ray inside the slab. Is it in the same direction as the incident ray or the emergent ray?

**What have you learnt?**

1. The ray of light changes its path at the point where it enters into the glass and also at the point where it leaves the glass slab, i.e., while travelling from one medium to other.
2. The ray of light is laterally displaced after passing out of the slab [Fig.10.9.6].

**Extension**

1. Repeat the activity by fixing two small pins A and B for incident ray and two more pins C and D for emergent ray.
2. If you have the common laser torch, which gives an instant thin light beam, you can repeat the activity by using a real light beam for incident ray (produced by the common laser torch) going parallel to drawing board about 5 mm above it. Fix the laser in a clamp stand. Mark two points in the centre of incident beam by a sharp tipped pencil, holding it vertically. Similarly, mark two points in the centre of emergent beam. Take care never to allow laser beam to directly enter the eye.

### **ACTIVITY 10.9.7 What happens when Sun rays are focussed by a convex lens on a piece of paper?**

#### **What is required?**

A convex lens (focal length 10 cm-15 cm) in a holder and a piece of thin black paper/carbon paper

#### **How will you proceed?**

1. Take a convex lens and hold it in your right hand such that it is normal to Sun light.
2. Hold a sheet of black paper in your left hand and move the lens towards or away from it till a sharp small spot of light is formed on the sheet.
3. This is the image of the Sun at the focus of the lens, and its distance from the lens is the approximate focal length of the lens.

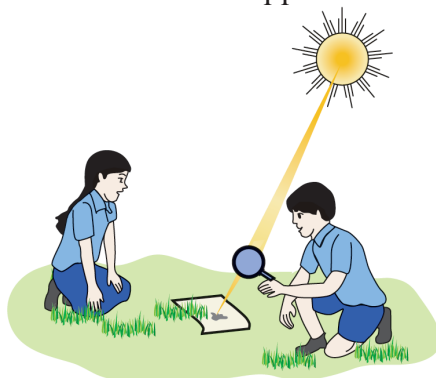

**Fig.10.9.7** A parallel rays of light the Sun are focused at a point

4. Hold the paper and the lens in the same position for some time and observe what happens to the paper.
5. Does the paper start smoking/burning after some time? Why does it happen?

#### **What have you learnt?**

A convex lens converges light (and heat also). The parallel rays from the Sun are focussed almost at a point.

#### **Extension**

Try to repeat the activity using white paper, instead of black paper. Is it easier by white paper? What problem do you face with white paper?

### ACTIVITY 10.9.8 How can the nature of the images of a lighted candle, be studied by a convex lens?

#### What is required?

A convex lens ( $f=10$  cm to 15 cm), lens holder, scale, candle, a screen mounted on a stand

#### How will you proceed?

1. Find the approximate focal length of the lens as in Activity 10.7. Let it be ' $f$ ' cm.

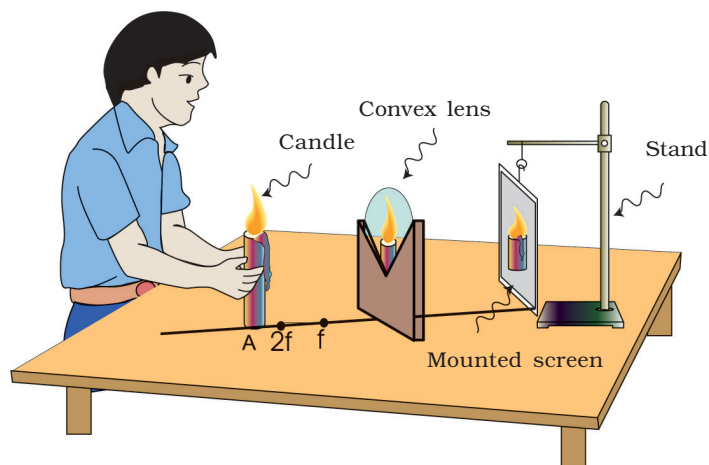

**Fig.10.9.8** Image formed by a convex lens

2. Draw a line on the table with chalk and mark mid point of it. Mark points at distance of  $f$  cm,  $2f$  cm, from the mid point, on both sides of it.
3. Mount the lens on its stand and put it at the mid point. Now place the lighted candle beyond  $2f$  on one side of the lens. Put the screen on the other side of the lens and adjust its position to get a sharp image of the candle flame on it.
4. Note the size (enlarged/diminished or of equal size) of the image.
5. Repeat the Steps 3 and 4 by placing the candle at various distances say at  $2f$ , between  $f$  and  $2f$ , at  $f$  and between  $f$  and the lens.

Note: If you can obtain the image on the screen in the last two cases.

**What have you learnt?**

1. When the candle is placed any where between  $f$  and infinity, the image formed by convex lens is real and inverted, but the image is not obtained on the screen when the candle is placed between the focus ( $f$ ) and the lens.
2. The size of the image depends on the distance of the candle from the lens.

## 10.10 Electricity

### ACTIVITY 10.10.1 Do components made of different materials offer different electricals resistance?

#### What is required?

Two dry cells of 1.5 V with a cell holder or a battery eliminator (0-6 V), a resistance coil, a 3 V torch bulb, a 100 W – 220 V or 60 W–220 V or 40 W–220 V or 25 W -220 V incandescent lamp with holder, multimeter used as an ammeter( 0 – 500 mA) and a plug key

#### How will you proceed?

1. Setup an electrical circuit with two dry cells of 1.5 V each in series (or eliminator set at 3 V), a plug key, a multimeter, leaving a gap X Y as shown in the [Fig.10.10.1].

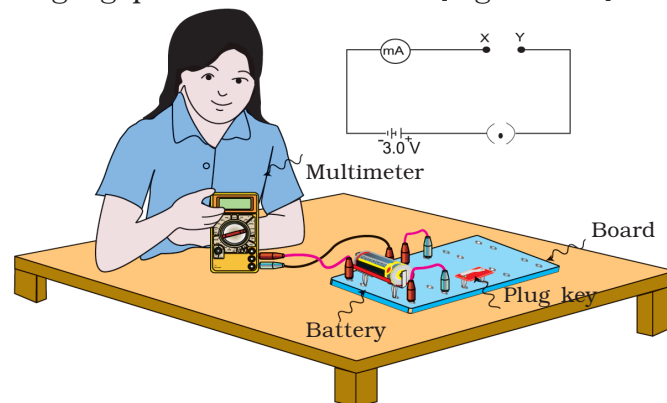

**Fig.10.10.1** Circuit arrangement to show different material components offer different electricals resistance

2. Connect the resistance coil in the gap X Y and note the ammeter reading after plugging the key.
3. Replace the resistance coil by a 3 V torch bulb and again note the ammeter reading. Is the ammeter reading in this case the same as before?
4. Further replace the torch bulb by a 220 V lamp in the gap X Y. What is the ammeter reading now? Is it same as in two previous cases?
5. What do you conclude from the above observations?
6. Try to find the reason for your above conclusion.

Note: Set the multimeter knob in d.c. (mA) mode.

**What have you learnt?**

Different components made of different materials offer different electrical resistance.

**Extension**

Repeat the above activity by inserting other components, such as incandescent lamps of other wattages, choke LED, etc. in the gap A B and note the ammeter reading in each case. Compare their resistances.

### ACTIVITY 10.10.2 What are the factors on which the resistance of a metallic conductor depends?

#### What is required?

One dry cell of 1.5 V with a cell holder (or eliminator set at 1.5 V), a tapping key, multimeter used as an ammeter, nichrome wires (SWG-24 – 50 cm, SWG-24 – 100 cm, SWG-28 – 50 cm) and constantan wire (SWG-28 – 50 cm)

#### How will you proceed?

1. Setup an electrical circuit with a dry cell of 1.5 V or eliminator, a tapping key K, an ammeter (0 - 3 A) and a nichrome wire of SWG-24 and length of 50 cm in the gap X Y as shown in the (Fig.10.10.2).

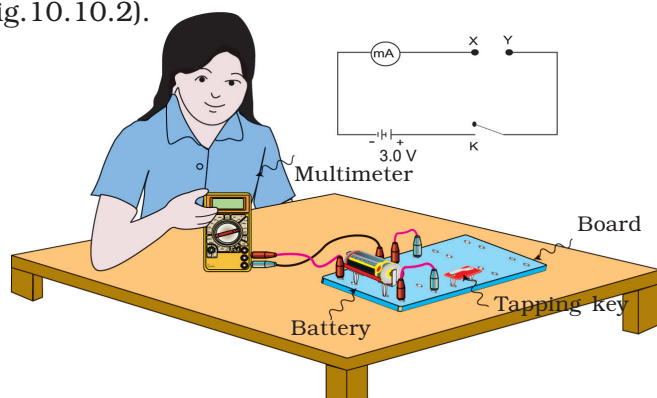

**Fig 10.10.2** Electric circuit to study the factors on which the resistance of a conducting wire depends

2. Close the circuit by tapping the key K and note the ammeter reading. Let us call this reading as A1.
3. Replace the wire by another nichrome wire of SWG-24 of length 100 cm and note the ammeter reading.
4. Is the ammeter reading the same as in the first case? Let us call this reading as A2.
5. Now replace this nichrome wire with another nichrome wire of SWG-28 of length 50 cm in the gap X Y and note the ammeter reading.
6. Is the ammeter reading the same as in the previous case? Let us call this reading as A3.
7. Repeat the activity by taking constantan wire of SWG-28 of length 50 cm. Let us call this reading as A4.



8. Now compare the ammeter reading A1, with the reading A2 , A3 and A4.
9. Why do you get different ammeter readings when the length of the wire, thickness of the wire and the material of the wire is changed?

Note: If the current drawn from a dry cell is more than about 500 mA, then it should be drawn for a few seconds only. Tapping key facilitates observance of this precaution.

**What have you learnt?**

1. Since the current flowing in the circuit decreases when the length of the wire is increased and thickness of the wire is decreased; the resistance of a wire:
  - (a) increases with increase in its length,
  - (b) decreases with an increase in its thickness or diameter.

The resistance of a wire also changes with the change in the nature of its material.

**Extension**

Repeat the activity by taking wires of different materials and different dimensions and further verify the above conclusion.

**ACTIVITY 10.10.3 Is the current passing through different points same in an electric circuit consisting of different resistors connected in series?**

**What is required?**

A dry cell of 1.5 V and a cell holder (or eliminator set at 1.5 V), multimeter (used as an ammeter), a plug key and three resistors of values 10 ohm, 20 ohm and 30 ohm

**How will you proceed?**

1. Arrange an electrical circuit as shown in [Fig10.10.3].
2. Note the reading of the ammeter.
3. Shift the position of the ammeter to the point B as shown in the figure.
4. Again note the ammeter reading. Is the ammeter reading the same or different?
5. Repeat the activity by shifting the position of the ammeter to the position C in the circuit. Is the ammeter reading the same or different?

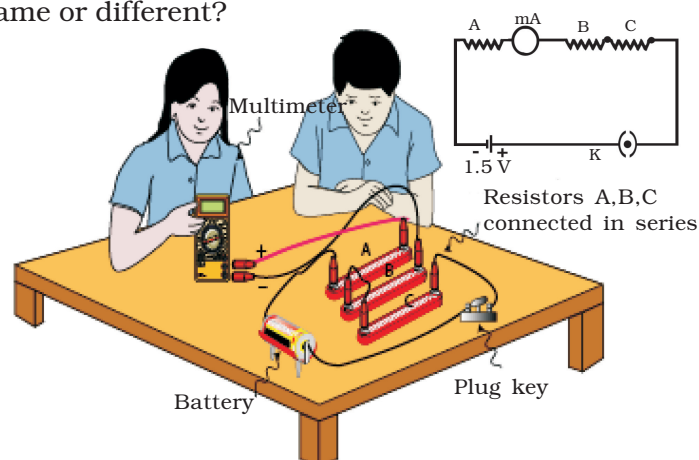

**Fig.10.10.3** Arrangement to show the current at different points of a series circuit

6. What do you conclude from your observations?

**What have you learnt?**

Since the ammeter reading remains the same whether it is connected in the circuit at position A or B or C, the current flowing through different points in a series circuit is the same.

**Extension**

Repeat the activity further by inserting more number of circuit elements and connecting the ammeter at different possible points in the circuit to confirm the above conclusion.

**ACTIVITY 10.10.4 Does the potential difference across different resistors connected in series in an electric circuit depend upon the value of a resistor?**

**What is required?**

Three dry cells of 1.5 V with a cell holder (or eliminator set at 4.5 V), a plug key, three resistors of values 10 ohm, 20 ohm and 30 ohm and a multimeter used as a voltmeter.

**How will you proceed?**

1. Connect an electric circuit as shown in the [Fig. 10.10.4].
2. Connect the voltmeter across 10 ohm resistor. Note its reading.
3. Shift the position of the voltmeter and connect it across 20 ohm resistor, without making any other change.
4. Again note the reading of the voltmeter. Is it the same or different?
5. Next, connect the voltmeter across 30 ohm resistor. Note its reading again. Is the reading the same or different?
6. Compare the readings of the voltmeter in these three cases.
7. How do you explain your observations?

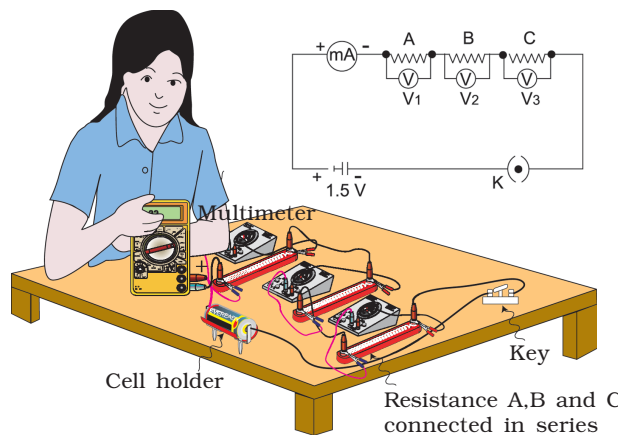

**Fig.10.10.4** Circuit arrangement to show the potential difference across different resistors

**What you have learnt?**

You have learnt in Activity 10.10.4 that the current flowing through resistors connected in series in a circuit is the same at all

points. Also, you observe that the potential difference (PD) across a resistor of larger value to be larger. This is in accordance with the Ohm's law.

**Extension**

1. The activity may be repeated by changing the number of cells in the circuit (or voltage setting of the eliminator).
2. Knowing the magnitude of current passing through the resistor and PD across each, you may like to find their resistance by Ohm's law.

**ACTIVITY 10.10.5 Whether the potential difference across the ends of different resistors connected in a parallel combination are the same? Is the current flowing through them are the same?**

**What is required?**

Multimeter (used as a voltmeter), three resistors of different values such as 20 ohm, 30 ohm and 50 ohm, two dry cells of 1.5 V each with a cell holder( or eliminator set at 3 V), multimeter (used as an ammeter) , a plug key and connecting wires

**How will you proceed?**

1. Join the three resistors, a voltmeter, an ammeter and a plug key with cells as shown in [Fig 10.10.5].

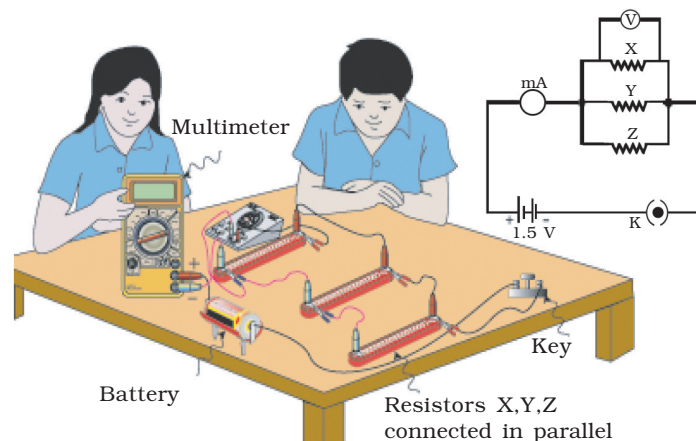

**Fig.10.10.5** Circuit arrangement to show the potential difference and current in a parallel combination of resistors

2. Plug the key and note the readings of the voltmeter and the ammeter, to find the potential difference (PD) across  $R_1$  and current through  $R_1$ , respectively.
3. Connect the voltmeter across the ends of the resistor  $R_2$  and ammeter at point Y to find the potential difference across  $R_2$  and the current through  $R_2$ . Plug the key and note these values.
4. Similarly, find the potential difference across  $R_3$  and current through  $R_3$ .
5. What is the relation between the potential differences in the three cases? Are they equal or different?

6. What is the relation between the current passing through different resistors? Are they equal or different?

**What have you learnt?**

In a parallel combination of resistors the potential difference across the ends of all resistors is the same, but the current flowing in each resistor is different.

## 10.11 Magnetic Effects of Electric Current

### ACTIVITY 10.11.1 Does a current carrying conductor produce magnetic field?

#### What is required?

Two dry cells of 1.5 V each and a cell holder or eliminator set at 3V, a tapping key, a thick copper wire in coil shape (preferably SWG-16) of about 20 cm length, a magnetic compass and two connecting wires

#### How will you proceed?

1. Using connecting wires connect the thick copper wire in coil shape with cells through a tapping key as shown in the [Fig 10.11.1].
2. Place a magnetic compass under the thick copper wire. Orient the wire parallel to compass needle. Observe the deflection of the needle of the compass on pressing the tapping key for a moment.

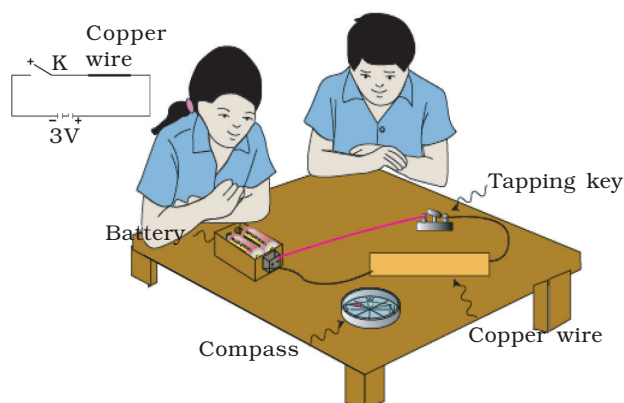

**Fig.10.11.1** Magnetic field is produced around a current carrying conductor

3. Reverse the direction of current passing through the copper wire by reversing cell connections. Observe the effect on the needle of the compass. Is the direction of deflection the same as before?
4. Open the tapping key. Current stops. Do you observe any deflection of the compass needle?



**What have you learnt?**

1. As the deflection of compass needle is caused by a magnetic field, a current carrying conductor produces magnetic field around it. As direction of deflection in the compass needle is reversed on reversing the direction of current through it, the direction of the magnetic field is reversed on reversing the direction of current.

**Extension**

Repeat the activity by keeping the compass above the thick copper wire.

**ACTIVITY 10.11.2 What is the the pattern of magnetic field lines around a bar magnet?****What is required?**

A bar magnet, fine iron dusts and a card board of size (20 cm × 15 cm) nearly.

**How will you proceed?**

1. Place the cardboard on a table.
2. Place the bar magnet in the middle of the cardboard.
3. Sprinkle iron dusts around the magnet on the cardboard. Tap the cardboard gently.
4. Observe the pattern in which the iron dust particles are arranged around the magnet on the cardboard.

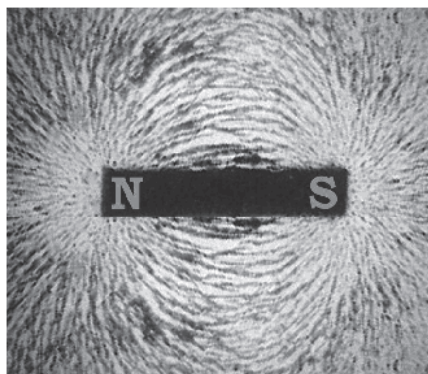

**Fig.10.11.2** Arrangement to show the magnetic field lines by using a bar magnet and iron dust on a cardboard

**What have you learnt?**

The iron dust particles align near the bar magnet in a particular fashion representing the magnetic field lines around a bar magnet.

**ACTIVITY 10.11.3 How to draw magnetic field lines around a bar magnet?****What is required?**

A small bar magnet, a magnetic compass, a drawing sheet, an adhesive tape and a sharp pencil

**How will you proceed?**

1. Fix the drawing sheet on a smooth table with adhesive tape.
2. Place the bar magnet in the middle of the drawing sheet and draw its boundary with a sharp pencil.
3. Place the magnetic compass near one end of the magnet (N-pole) and mark the positions of the two ends (N-and S-poles) of the compass needle using a sharp pencil.
4. Shift the compass from this position and place it in such a way that S-pole of its needle is on the point you marked in previous step for N-pole.
5. Again mark the position of the other end (N-pole) of the compass needle.
6. Repeat the Steps 4 and 5, till you reach the other end (S-pole) of the bar magnet.
7. Join all the points with a sharp pencil to get a smooth curve.
8. Put the compass at some other points near the N-pole of the magnet and draw another magnetic field lines. Similarly, draw many field lines on both the sides of the bar magnet as shown in [Fig.10.11.3].

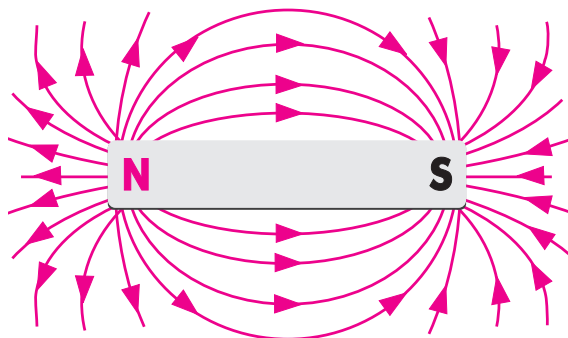

**Fig.10.11.3** Drawing magnetic field lines around a bar magnet

9. Observe the pattern of the magnetic field lines. Do the field lines cross each other anywhere in the whole pattern?

**What have you learnt?**

Magnetic field lines can be drawn around a bar magnet using a magnetic compass. The field lines do not cross each other.

**Extension**

Repeat the activity by placing the magnet along any other direction and observe the pattern of the magnetic field lines near it. Is it similar to the previous pattern?

### ACTIVITY 10.11.4 How does a current carrying circular coil produce a magnetic field?

#### What is required?

A circular coil (having about 500 turns and internal diameter about 10 cm) fitted with a board in a horizontal plane through its centre, a plug key, iron dust and about 12 V DC obtained by 8 cells in 4 holders each containing 2 cells

#### How will you proceed?

1. Connect the ends of the circular coil in series with the four 2-cell holders, plug key as shown in [Fig 10.11.4].
2. Sprinkle iron dust particles on the board as uniformly as possible.
3. Complete the circuit by closing the key K.
4. Tap the cardboard gently a few times and observe the pattern in which the iron dust settles on the board.
5. How does this pattern look like?
6. What does it indicate about the nature of magnetic field produced by the current carrying circular coil?

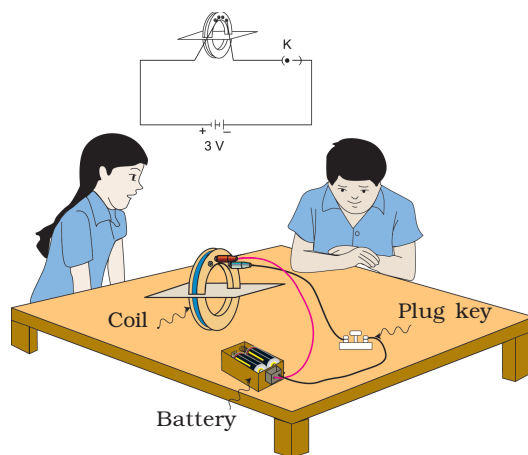

**Fig.10.11.4** Pattern of magnetic field lines produced by a current carrying circular coil

#### What have you learnt?

The pattern of the magnetic field lines near the wires of the coil are concentric circles. The diameter of these circles goes on

increasing as we move away from the points where coil enters the board.

**Extension**

Change the direction of current by altering the connections of the battery. Repeat Step 4 and observe if there is any change in the pattern.

**ACTIVITY 10.11.5 How does a conductor placed in a magnetic field behave when a current is passed through it.**

**What is required?**

A disc magnet, a stout metal (copper) wire bent in the form of U with hooks at both end, two cells of 1.5 V each with a cell holder, a wooden stand, a tapping key and connecting wires

**How to proceed?**

1. Suspend the metal wire (U-shaped) on a wooden stand as shown in [Fig 10.11.5].
2. Place the disc magnet just below the horizontal arm of the copper wire as shown.
3. Tap the plug key to pass momentary current through the copper wire.

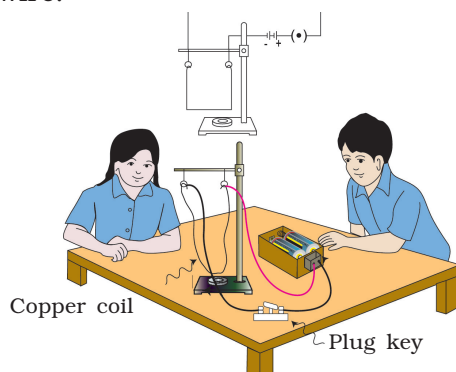

**Fig. 10.11.5** The force experienced by a current carrying copper wire placed in a magnetic field

4. Observe the effect on the horizontal part of the copper wire. Is there any motion in it? Note the direction of its first motion, because after that it oscillates.
5. Reverse the direction of current in the circuit by reversing connections of the cells. What do you observe for the first motion of wire now?
6. Instead of reversing the direction of current as in Step 5, reverse the disc magnet (upside down) to change the direction of magnetic field across the wire.
7. Again complete the circuit and see the motion of the copper wire.

8. On the basis of your observation, draw conclusions. Are these in accordance with the Fleming's left hand rule?

**What have you learnt?**

When a current flows through a conducting wire placed in a magnetic field, the conductor moves in accordance with the Fleming's left hand rule.



**ACTIVITY 10.11.6 What happens when a magnet is moved near a coil of wire?****What is required?**

A bar magnet, circular coil having about 500 turns of insulated copper wire and 10 cm internal diameter fitted on a board, a multimeter (used as micro-ammeter), a plug key and connecting wires.

**How will you proceed?**

1. Place the coil on the table and connect a micro-ammeter to its two ends. Is there any reading in the micro-ammeter?
2. Keep a bar magnet on the board fixed with the coil. Do you see any reading in the micro-ammeter? Repeat your observation by placing the bar magnet at different positions in the board.
3. Hold the bar magnet in the board such that it can be moved along the axis of the coil easily.
4. Move the bar magnet towards the coil. Do you see any deflection in the micro-ammeter needle? If yes, what does it indicate?
5. Move the bar magnet away from the coil. Is there any change in the direction of the deflection of the micro-ammeter needle? What does that show?
6. Repeat Steps 4 and 5 by reversing the poles of the bar magnet.
7. Now conclude your observations.

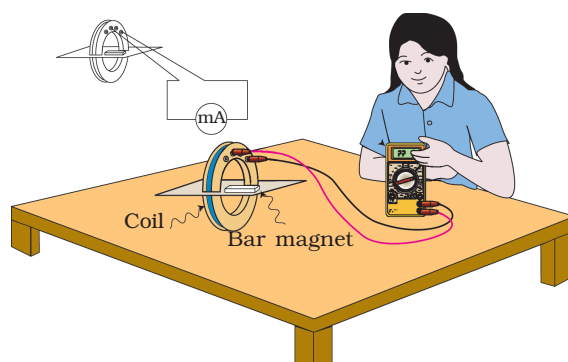

**Fig.10.11.6** Electric current is generated in a circular coil due to the motion of a bar magnet in the coil

**What have you learnt?**

1. As the reading of the micro-ammeter needle indicates the flow of current in the coil. Current is generated when the coil and the magnet are stationary relative to each other.
2. A current is generated in the coil whenever there is a relative motion between the coil and the magnet.
3. The direction of current changes when the direction of motion of the magnet changes or the polarity of the magnet is changed.

### ACTIVITY 10.11.7 What is the effect of varying the current in a coil on placing another coil near it?

#### What is required?

One circular coil of about 500 turns, another circular coil of about 20 turns, two cells of 1.5 V each with a cell holder, millimeter used as a micro-ammeter, a tapping key and connecting wires

#### How will you proceed?

1. Place the two coils on the table coaxially with their faces facing each other.
2. Connect the two terminals of 20-turn coil to the micro-ammeter and the two terminals of the 500-turn coil to the cells through a tapping key as shown in the [Fig.10.11.7]

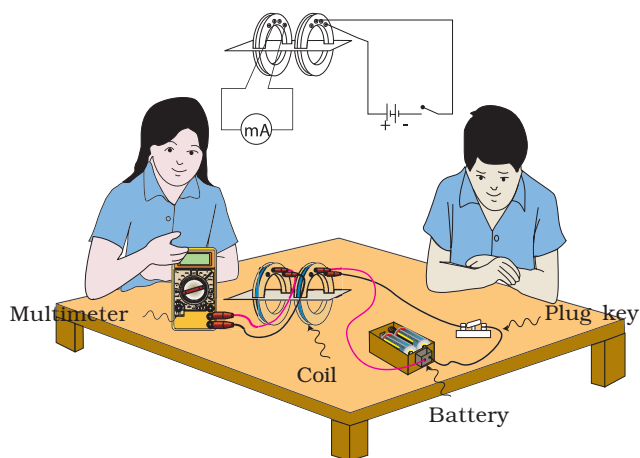

**Fig. 10.11.7** Arrangement to show electromagnetic induction

3. Close the key for a moment and note whether there is reading in the scale of the micro-ammeter and note simultaneously whether it is positive or negative.
4. Repeat Step 3 at least 3-4 times.
5. Reverse the direction of current by reversing connections of the cells and repeat the Step 4. The moment tapping key is pressed the scale of the micro-ammeter instantly shows a reading and just as quickly returns to zero. On reversing

the direction of current the scale of the micro-ammeter shows a reading but now of opposite sign.

6. Draw conclusions based on your observations.

**What have you learnt?**

1. Whenever there is a change in current flowing through a coil a current is produced in a neighbouring coil. This current produced in neighbouring coil is called induced current.
2. When there is no change in the current in the first coil, no current is induced in the second coil.

## Do You Know

According to the 86<sup>th</sup> Constitutional Amendment Act, 2002, free and compulsory education for all children in 6-14 year age group is now a Fundamental Right under Article 21-A of the Constitution.

**EDUCATION IS NEITHER A PRIVILEGE NOR FAVOUR BUT A BASIC HUMAN RIGHT TO WHICH ALL GIRLS AND WOMEN ARE ENTITLED**

*Give Girls Their Chance !*



**Molecular Model Kit**  
आणविक मॉडल किट

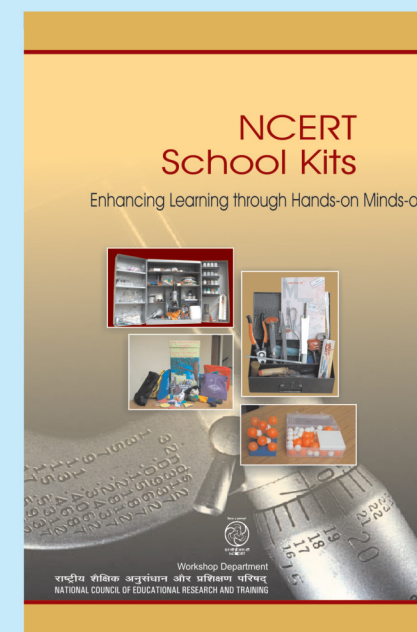

**NCERT**  
**School Kits**

For further enquiries, please visit [www.ncert.nic.in](http://www.ncert.nic.in) or contact the Business Managers at the addresses of the regional centres given on the copyright page.